

ϕTensil

Fiam Electric Tightening Solutions

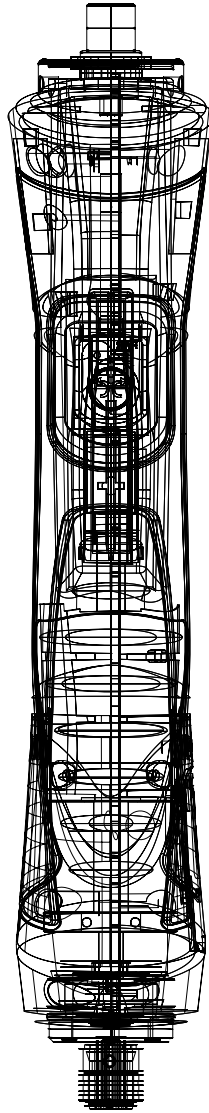

Electric solutions with mechanical clutch and automatic shut off:
screwdrivers, nutrunner motors and solutions for automation.
Monitoring unit with advanced programming.



Fiam
PEOPLE AND SOLUTIONS

eTensil. Fiam's electrical revolution.

With eTensil, Fiam sets the benchmark in the world of industrial tightening. We have supplemented our tried-and-tested air solutions with a range designed and manufactured to raise the bar in manual and automatic tightening through electric tools.

Electric, efficient and accurate, eTensil is the home-grown response to this modern industry's demand for green, versatile and intelligent tools. We have designed them to slot seamlessly into the most up-to-date manufacturers and their working processes: from precision mechanics to automotive, from electronics to household appliances assembly. Design, power, precision in construction and excellence in manufacturing are the cornerstones that make eTensil a proudly Italian solution. This is a systematic project in which every detail has been developed and elaborated around top performance.

Power supply and monitoring unit

p. 4



Manual tightening systems

p. 10



Accessories for ergonomics and screws positioning devices

p. 26

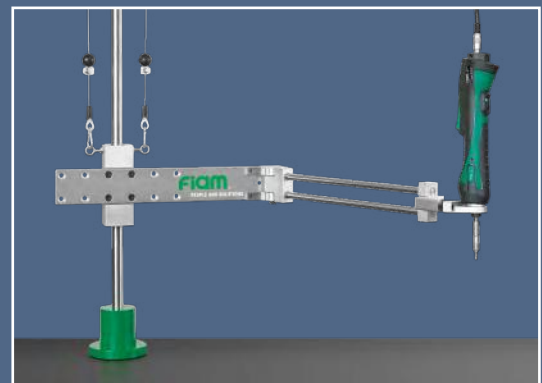

Automatic tightening systems

p. 28



Power supply. Intelligent energy.

The basic power supply units work in perfect synergy with the tool providing the **right electrical power levels appropriate for each operational mode** while constantly monitoring screwdriver's status and the whole tightening process. The units are also used to activate various functionalities and increase programmability and other customisable features, for which the screwdriver is designed.

1. Functional design.

Functionality and aesthetics combine into a power supply design perfectly matched to Fiam's style. Designed in the Research and Development department in conjunction with an Italian design studio, these units capture the same colours and style as the screwdriver range. The casing has been created using an exclusive mould, in a shape perfect for housing the internal technology that still **allows the user practical access** to required functions while the visual signals on the back remain visible. These features are accompanied by a **sturdiness** that makes each unit perfect for a vertical clamp, as a practical alternative to placing the unit on the working horizontally.

2. LEDs.

A power supply and control system is installed inside the unit, which Fiam has designed and created so that **tightening can be managed in a synchronised and efficient way**. High-visibility LEDs are linked to the control devices inside so that the status of key procedures (such as **correct functioning, selected speed, clutch being engaged, anomalies, emergencies**) can be consistently monitored. This means all production activities continuously increase in efficiency.

3. Two models, endless possibilities.

The TPU 1 model guarantees each screwdriver receives the **correct electrical supply**, as well as allowing the user to monitor key working procedures. The TPU 2 model with "optoisolated" input and output signals allows **activation and remote control of some functionalities and results**. The unit can handle 5 input signals for activating various functionalities and 5 output signals to indicate the completion of a work process or the screwdriver's status.

4. Tool/motor speed selection.

A membrane switch allows the user to set **two rotation speeds** LOW/HIGH (slow / fast) both in tightening and untightening. LOW is a reduction of a screwdriver's maximum speed (on the motor nameplate) by approximately 20%. The parameter is independent and it is possible to use HIGH in tightening and LOW in untightening and vice versa.

Power supply: TPU 1 and TPU 2 models.



A.
Green LED: clutch shut off and motor stop.

B.
Red LED: error (stalled motor) or "Button" + push to start activated.

C.
Red LED: screwdriver not enabled (external signal stop, activable only in the TPU 2 model).

D.
Status LED (system on/off).

E.
S1 - In the TPU 1 model the LED is always on
- In the TPU 2 model, the LED lights up indicating the activation of the emergency on an external signal.
S2 - Tool ready to use.
S3 - Tool in use (RUN).

F.
Button for selectong LOW/HIGH (slow / fast) tool speed.

G.
Port for connecting the supply cable to the screwdriver.

H.
Start up button with light.

I.
Port for electrical power supply cable.

L.
Port in TPU2 version:

Input signals

1. H/L speed
2. Motor stop
3. Reverse
4. Emergency
5. Start

Output signals

1. Ready
2. Stalled Motor
3. Run
4. Reverse
5. Clutch engaged

Performance and functions. Exclusive programming.

With TPU 1 and TPU 2 units, it is possible to **set manually various work processes on the tools themselves**, without having to change the mechanical setup or having to deal with an external accessory. This strategic choice defines eTensil as one of **the most evolved solutions in terms of efficiency and versatility**.

5. TPU 1 and TPU 2: Exclusive “Smart Pro” Programming, directly on the tool.

eTensil is the unique screwdriver that allows the change of the start up modality without modifying the mechanical setup.

Pressing the reverse button for at least 4 seconds activates the programming of the different functions that can be selected by clicking on the lever.

FOUR DIFFERENT PRE-SET START UP MODALITIES and selectable directly from the tool

- The modalities are:
- Lever start
 - Push to start
 - Lever start + push to start
 - “Latched lever” + push to start

Additional SIX functions can be activated by pressing and holding the reverse button for at least 4 seconds while pulling in the lever.

This procedure allows to switch the following functions on/off:

■ **STARTING BLOCK** (in case of an anomaly)

■ front **ILLUMINATION LED**

■ **INHIBITION OF UNTIGHTENING** by setting this option the tool will no longer start in left rotation

■ **SOFT START:** slow screwdriver start (from stopped to rated speed in approx. 1.5 seconds)

■ **PRE-AUTO UNTIGHTENING** by 4 turns (1440 degrees). A useful feature when you have previously tightened parts that need loosening before being tightened to the set torque

■ **POST-AUTO UNTIGHTENING** by 4 turns (1440 degrees). A useful feature when needing to tighten to the set torque and then loosen for a subsequent assembly.

"Smart Pro" Programming.

Pressing the reverse button for at least four seconds activates programming of the different functions through the lever.

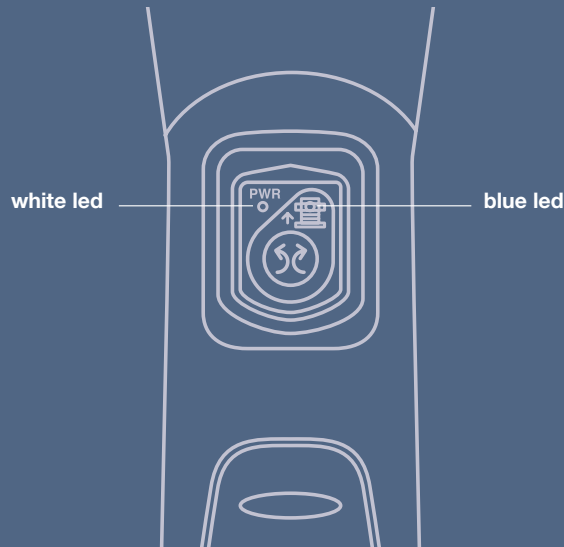

Four start up methods.

eTensil is the top choice when it comes to functionality, as **the only screwdriver on the market that allows the user to change work modes quickly and efficiently** without changing the mechanical set up.

There are four presets:

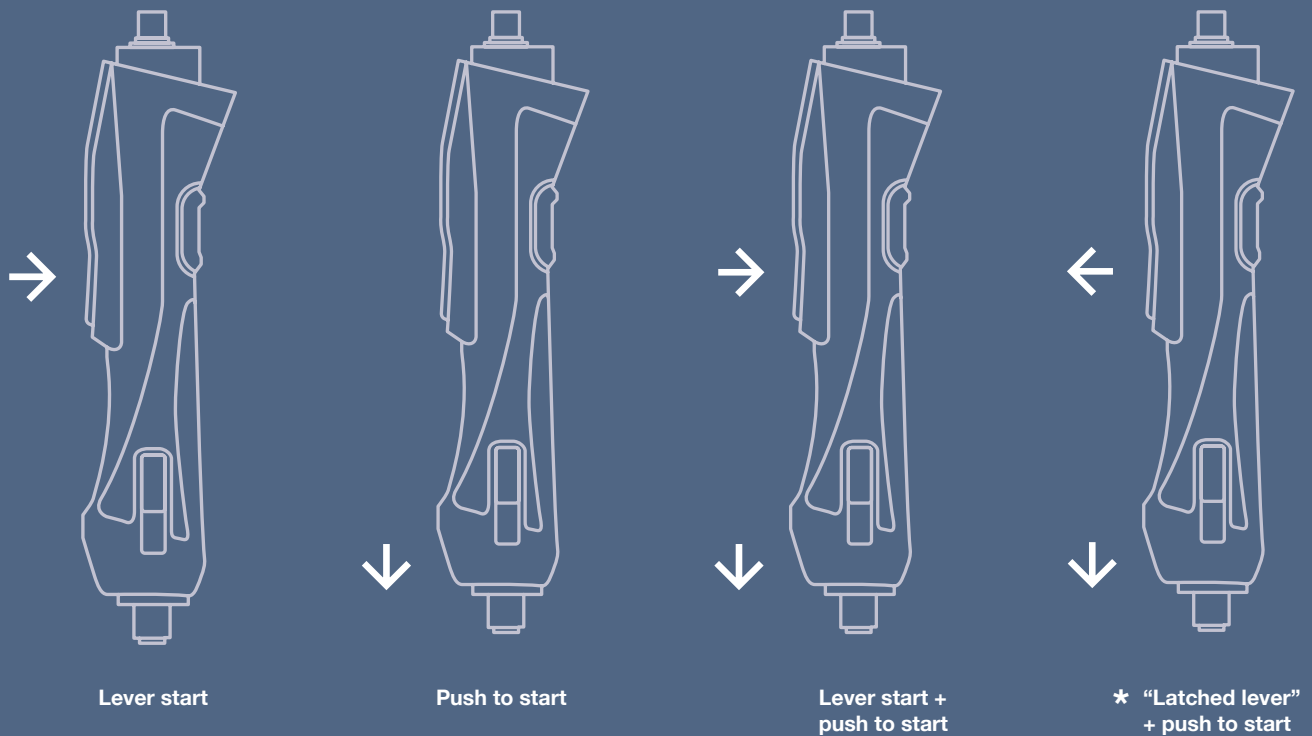

* The "latched lever" + push to start mode allows the screwdriver to work without need to keep the lever pressed. For safety, the screwdriver activates only when pushing on the bit. In this mode, the first pressure applied to the lever starts the screwdriver until clutch shuts off, whereas a second pressure can eventually stop it before the working cycle is completed.

Monitoring Unit.

Advanced power.

TPU-M1 monitoring unit represents a **great innovation able to monitor and manage all the functions of the matched tool**. A sophisticated instrument designed not only to provide the tools with the correct power supply, but also to handle **large number of functions that can be programmed quickly, easily and intuitively**.

Designed and built entirely by Fiam, it represents a strategic choice providing one of the most advanced solutions for the industrial production.

6.

TPU-M1: to manage a tightening process correctly and quickly

AUTOMATICALLY AND IMMEDIATELY RECOGNIZING THE CONNECTED TOOL
and setting the applicable parameters range for it.

SCREW COUNTING
this function turns the system into an effective Poka Yoke device.

STORING
the outcome of the last 99 cycles.

SIGNALING LEDs.
The high-visibility LEDs placed above the display allow immediate viewing of the process status. For a synchronized and efficient tightening management:
Red LED = Nok
Yellow LED = End of cycle
Green LED = Cycle progress (screws tightened)

according to the set number of screws.

CHECK TIGHTENING TIME
to detect process anomalies like overtreading and already tightened screws.

COMMUNICATION WITH MASTER PLC
and others devices:
8 + 8 signals I/O freely programmable that offer several functionalities to be chosen from 21 + 22 signals.
Allow to communicate the phase, the system status and to control the tool in **remote**.

DISPLAYING OF TIGHTENING RESULTS OK/NOK
in addition to the tightening time.

INTERFACING WITH WORKING STATIONS
if there are workpiece clamping jigs, the piece locking devices can be activated / deactivated.

8 MONITORING PROGRAMS
The programs can be managed remotely in single mode or with binary combination.
Also, with each program, there can set **both the number of screws to tighten and the timeframe window to conclude the tightening cycle.**
For example, if there are 5 screws to tighten, out of which 3 with 5 mm length and 2 with 10 mm length: there can be set two programs to work in sequence. The first program will include 3 screws and a maximum time 0.5 sec. Second program for 2

screws with a maximum time of 1.1 sec.

So, through the stop - by - time tightening, it is possible to discriminate the length of different screws.

SOLVE TIGHTENING WITH CRITICAL JOINTS
An advantageous **Poka Yoke system** to manage for example assembly with elastic gaskets, or components made of rubber or other materials.
In all these situations, it is possible to **verify that gaskets are in place** by comparison of the detected angle respect to the set range.
An essential stratagem for the productivity and final product quality.

TPU-M1 Monitoring Unit.



TPU-M1

- 8 programs to control tightening process
- 1 programmable sequence up to a max of 8 steps
- Automatic recognition of the tool and configuration
- Screw counter - Poka Yoke system
- OK / NOK: tightening result displayed
- Min / Max tightening time control - Poka Yoke system
- Settable untightening speed
- 2 levels password: to protect the set parameters or totally block the system
- Serial communication (RS232)
- Language selection (IT, EN, DE, FR, ES)
- Log of the last 99 tightenings
- Interfacing with working stations
- 8 + 8 programmable I/O (21 + 22 signal types)
- Selection of programs from I / 0 (remotely)
- Min / Max tightening angle control - Poka Yoke system

SMART PRO EVO PROGRAMMING

- 4 start-up modes selectable on the unit
- Soft Start - acceleration ramp
- Settable rotation speed
- Pre-auto untightening (can be activated with all tightening strategies)
- Post-auto untightening (can be activated with all tightening strategies)

TIGHTENING STRATEGIES

- Torque control with mechanical clutch
- Torque control with mechanical clutch and tightening time monitoring
- Time control (Stop-by-time tightening)
- Angle control and tightening time monitoring

FUNCTIONAL DESIGN

Functionality and aesthetics combined in the monitoring unit design, allowing **practical access to the operating panel**. These features together with the sturdiness make this unit perfect for a **vertical clamp**.

“SMART PRO EVO” Programming.

In addition to the Smart Pro programming modes directly on the tool illustrated on page 6, with this advanced unit and the Smart Pro Evo programming, you can also manage:

FOUR DIFFERENT PRE-SET START UP MODALITIES can be set on the monitoring unit:

- Modalities are:
- lever start
 - push to start
 - Lever start + push to start
 - “Latched lever” + push to start.

FRONT ILLUMINATION LED

with intensity adjustable from 0 to 100%.

UNTIGHTENING FUNCTION activable/deactivable. Settable untightening speed.

SOFT START function settable: it is possible to set the time acceleration to ease screw engagement.

TOOL SPEED can be freely set within minimum and maximum range, both in tightening and in untightening.

Other additional adjustable features:

- **PRE-AUTO UNTIGHTENING** it is possible to set the **untightening angle and the pause between the untightening and the subsequent tightening**. This strategy finds its

application in the electrical / electronic field, for example when it is necessary to open and then close connectors to insert electrical wires.

- **POST-AUTO UNTIGHTENING** the **untightening angle** is settable as well as the time pause of left rotation start after the tightening end.

- **STOP-BY-TIME TIGHTENING** when it is necessary to tighten in **depth and not to defined torque**, by controlling the cycle with set tightening time.

Production efficiency. Precision at work.

Production efficiency defines eTensil. The whole project is tightly wound around perfecting the key functions that ensure **precision, power and control** at all times when using a screwdriver. The advantage to this is a **high-quality final product**.

7. Torque control system with mechanical clutch.

This control system is vital to **tightening torque**, as it automatically cuts off the power supply. This ensures **high repeatability** - in other words a low Mean Shift value - **even when faced with a variable joint softness level**. Values remain unchanged over **million of cycles**, guaranteeing high quality that is consistent over time.

8. Signaling LEDs.

Three LEDs ensure precise and efficient signaling. It is a simple solution that ensures the screwdrivers' settings and correct functioning are immediately apparent to the user. **The blue LED** near the reverse button remains lit to signal that the screwdriver is in "untighten" mode (leftwards rotation). **The white LED in the same area** shows the tool is ready for use. **The LED at the front**, next to the quick change chuck, lights up the area of work as well as indicating anomalous functioning at the end of a tightening cycle (in conjunction with the blue LED). Once the same LED flashes constantly it means that the programmed maintenance is required.

9. On board electronics.

FIAM has designed and created an **innovative on board electronics** so as the user can easily configure various settings directly on the tool, instead than on the power supply unit. As a result the system is easier to use, workplace layout is tidier, and data exchange between the tool and the power unit is faster.

10. Mechanical clutch control.

eTensil comes in two versions:

■ **SAFE CLUTCH CONTROL**
A **protective device** controls access to the mechanical clutch, ensuring adjustments are made safely. This **keeps tightening torque repeatability consistent** and tightening precise and safe, so as to adhere to the highest manufacturing quality standards.

■ **QUICK CLUTCH ADJUSTMENT**
When dealing instead with the need to **swap often between the components to be assembled and relevant screws**, models with external clutch adjustment are the ideal solution, allowing you to **quickly and repeatedly adjust tightening torque on the outside of the unit**. The ring is numbered for even easier immediate adjustment.



Reliability. A project for the long-term.

eTensil components are built to guarantee the highest levels of **reliability and safety** throughout the life cycle of any operation. The engineering involved in the mechanics, the elegance of this executive range and performance tests passed, all arise from **Fiam's existing wealth of knowledge and specialist patents in the industrial tightening industry.**

11. Latest generation brushless motor.

Brushless motors are the avant-garde in efficient and consistent performance, due to their **high-precision mechanics.**

eTensil has been designed in order to obtain endless electric lifespan, thanks to the implementation of low wearing components, to low motor inertia and to a lower heating of the assembly. Hall sensors allow the user to **have full control of rotation** and ironless systems **make the motor so light.**

12. Reduction assembly.

Increased performance in output, **duration and noise level are the principles** that guide the latest designs in gear assembly - aims we have achieved through research focused on ensuring gear lifespan and efficiency as well as the careful sizing and the incorporation of treatment options into the manufacturing cycle. **Such innovative** ways of working mean the gear assembly remains practically **unchanged** even after **thousands of operational hours**, as our lab tests prove.

13. Modular structure.

Functionalities integrated into the circuit board, reduced and simplified electrical connections, its clean design, the modularity and the seamless integration of electronic components into the mechanics; all bases of the constructive **strength, designed to last and guarantee safe** and efficient servicing.

14. Connection cable screwdriver - power supply.

The cable is **extremely flexible**, with **sturdy connectors**, designed to last over time and made entirely in Italy upon Fiam's specifications. Standard length is 3 metres, which can be increased by adding additional cables. **Extremely resilient**, flame resistant and hallogen-free, designed to resist oils and to face extreme conditions of use in an industrial environment.



Ergonomic design. Perfection in handling.

eTensil design takes care of both **appearance and functionality**. Ergonomics has always been the central point of Fiam design and key strength in provided solutions. In perfect Italian style, the design also adheres to the combination of form and matter, with linearity and refined layout.

15. Ergonomic grip.

The grip has been designed and manufactured with the clear goal to reduce any fatigue and optimize productivity. Materials, horizontal grip-shaping, and the casing layout provide a stable rest point for the hand. All such details reveal a research for functionality and aesthetics. The grip is made of **innovative materials** ensuring a better resistance against any form of collision or damage. It is placed close to the tightening area, making the centring easy and fast. Easy to handle, **combining low** weight and dimensions. Suitable for both left and righthanded users, as **well** as for the **smaller and female hands**.

16. Reduced-effort start up.

The **pressure required to activate** lever start up is **much lower** than others available on **the market**. **Reducing the effort** the user needs to sustain over the course of the working day, will result in increase of production efficiency. The **start up lever** is another “**smart**” device in the system. It is of the contactless type, it is activated thanks to an analog sensor with **exceedingly sturdy mechanics/ electronics** that are **not susceptible to wear**. Pressed, it slots perfectly into the tool’s casing thus **ergonomically supporting to the user’s hand**.

17. Reversibility.

The reverse command is encased within the screwdriver body to protect it from wear, collision or damage and accidental activation. A single press of the **button when the screwdriver is** not in action inverts the rotation (indicated by the blue LED). Holding the button for at least four seconds starts up the “**SMART PRO**” **programming mode**, indicated by the LED flashing (programming can be done with TPU 1 and TPU 2).

18. Noise level and comfort.

eTensil ergonomic design also ensures low noise and comfort. All of the screwdrivers’ mechanical elements have been designed to be **noiseless** - motor, gears and clutch. The tool is equipped with quick change chuck: easy and safe to use, it allows the user to quickly change bits. The presence of a **suspension device** eliminates the need for the user to support the tools. All of these features are essential to eTensil’s unparalleled ergonomics.



Several configurations. Catering to all production needs.

On production lines, the components to be assembled inevitably come in numerous different versions, thus entailing the use of different types of screws, in addition to differing geometries. Manual workstations managed by operators hence need an extreme level of production flexibility, which entails the use of **suitable tools and essential measures to reduce fatigue**.

19. Screw suction device.

This device makes the tool's hold on the screws and their positioning easier and more secure and can be fitted on all straight screwdrivers and on eTensil motors. Simply fit the screwdriver with a **special head** connected to a vacuum pump. Attached to the head is a special **nozzle** that can be customized to suit the screws in question or the part to be assembled. The bits are also adapted to suit the screw type.

20. External clutch adjustment.

When dealing with the need to **swap often between the components to be assembled and relevant screws**, models with external clutch adjustment are the ideal solution, allowing you to **quickly and repeatedly adjust tightening torque** without having to get inside the screwdriver. The ring is numbered for simple and immediate adjustment. Models available with lever start only.

21. Angle models for reaching every point.

In the automotive and household appliance industries, where tightening has to be done in tight and hard-to-reach spaces - for instance, up against walls, near to frame members and profiles - the ideal solution lies in angle screwdrivers. **Their 30° or 90° heads - which are extremely compact** to reach awkward tightening sites - have been **designed and manufactured with innovative materials** that make them **wear resistant** (and hence low maintenance), while delivering **impressive tightening precision**. Models available with lever start only.

22. Pistol models.

Straight screwdrivers demonstrate their versatility even as **operating layouts change**: if tightening points happen to be located on a vertical wall, they can be converted to pistol screwdrivers, making the tightening job 100% ergonomically sound. The pistol grip - available on request - results in an extremely balanced new grip that is also suitable where hanging systems are not an option and where particular thrust is not required along the tightening axis.



Safety. Green performance.

Fiam has always **considered as a priority the safety of the working tools**, which play a vital role in the assembly process. The eTensil project has grown into its current strategical importance over a long **certification process** that has involved collaboration between Fiam and three external laboratories in a series of “pre-compliance” tests. Fiam guarantees that its range of electric screwdrivers **fully complies with latest electrical safety, EMC and ESD directives**.

23. Low environmental impact.

No sliding electrical contact in the brushless electric motors prevents carbon and blade dust emissions thus creating a safer working environment. All eTensil components are made of **recyclable materials**, making it easy to dispose of them.

The entire system in every element of the eTensil screwdriver range has been designed with the Life Cycle Assessment in mind: from supply chain to finalisation, from production to product transport, from usage to disposal.

24. ESD certification.

Casing of eTensil range has been made using the latest technology in ESD dissipative plastic, **thus avoiding the build up of electrostatic charge**. Any electrical charges transferred by the user to the tool (and vice versa) are discharged to the ground **without intruding upon the tightening area**. In compliance with the latest European Directives, the eTensil range **is immune to electromagnetic disturbances** generated by cables or as a result of the interference of other devices. The tools do **not influence** other devices either. This is a huge advantage when **assembling high-quality electrical components** that must be protected from the build up of electrostatic charge.

25. “Dust proof” construction.

The casing of eTensil is designed and manufactured to reduce as much as possible dust and other waste or substances infiltrations, that can compromise functionality of the tool. The most exposed parts of the screwdrivers are **duly sealed**. This greatly reduces potential functioning issues linked to external, damaging factors. In addition, all labels are enclosed within the casing to keep them protected from wearing and ensure traceability.

26. Maximum safety.

Operating at low-voltage (32 volts) means **maximum safety**. Special ergonomic grips guarantee perfect **thermal isolation**.



Continuous monitoring. Controlled production.

The eTensil range is designed for integration with **production cycle monitoring systems**, such as TOM and TPM units. Also produced entirely by Fiam, these systems are equipped with a series of acoustic and visual alerts, allowing users to continuously monitor work processes, thus guiding them through the assembly stages. These systems eliminate post-process controls, they are easy to use and intuitive to set up. Moreover, when connected to the line's PLC, they remotely communicate with a factory system in order to transmit production data (Industry 4.0) and cycle efficiency.

27. TOM. Tightening Operation Monitor.

TOM is a "Poka Yoke", error proof system designed to eliminate errors in context of lean production.

In-process controls of tightening progress provide full support for users, including updates on the outcome of each cycle and permission to begin each subsequent step accordingly. If there is an error, at the end of a cycle users are presented with the option to halt the production line. This supports users by giving them constant control over the machine's functions and the ability to **monitor the entire process**.

Connecting TOM to a printer generates **reports on all the tightening procedures executed** for each item or on the entire production process.

Error rate: 0%.

The ability to see errors and halt production translates into zero waste. The double display provides immediate feedback on the production process under way. The system registers each tightening process separately, deducting each one as it is completed.

TOM is equipped with **4 acoustic alerts** (successful tightening, end of process, error, end of sequence) and **3 LEDs**. As an alternative to the line's PLC, users can connect the inputs/outputs to their own pick-and-place systems, warning lights, devices to block/activate start-up and positioning jigs. There are many advantages: **safety, speed and efficient maintenance.**

28. TPM. Tightening Position Monitor.

TPM is an auxiliary system that increases the efficiency of tightening operation cycles by monitoring all the sequences concerned with tool positioning **at the tightening point**. This consists of a **telescopic magnesium arm** and a **TPM monitoring unit** that both guides users through the operations and ensures that the **final product is assembled in line with the required specifications**. The telescopic arms can be supplied with the TPM and come in two versions: one allows the device to perform **angular movement detection**, another **angular and linear movement detection**.

Guided positioning.

The system locates the screwdriver's position in a tightening process and stores this in its memory. It also stores the sequence of actions and the number of screws used. Storing this information is part of the system's "self-learning" process. The screwdriver activates when it finds the first position stored in its memory: POS-OK appears on the TPM display and the POS-OK LED on the telescopic arm lights up. For every screw tightened, the REMAIN display indicates how many screws are left to tighten, allowing the system to proceed to the next one. The END signal lights up once the memorised cycle is complete and permits users to proceed to a new working cycle.

TOM.



It works when connected to the TPU 2 power supply.

Single programme (99 screws per programme) or sequences of several programmes (up to 8).

Programmes can be selected from an external PLC using available input/output signals (20 inputs, 24 outputs).

RS 232 port for printing reports.

Memory: Items OK - incorrect tightening - Reset activated (rejected items) - stores up to 6,000,000 tightening processes.

Double display for viewing immediate feedback on:

- no. of activated program;
- no. of set sequence;
- no. of screws to be tightened;
- no. of screws tightened (of total).

TPM.



Up to 35 positions/screws per programme, up to 8 programmes.

When programming the sequence and positions, users can set a

precision tolerance depending on the extension distance: e.g. $\pm 10\%$ for a length of approx. 1 mm; 0.1 degrees for an angle (maximum tolerance).

The large graphic display guides users step-by-step towards the tightening point. Once reached, all the green LEDs light up to signal

that the user may proceed with the tightening process; the small display instead shows the number of screws left to tighten.

Screwdrivers technical features.

	Type of screwdriver	Code	Grip	Tightening torque		* Idle speed range with TPU M1	* Idle speed slow-L / fast-H with TPU1 and TPU2	Starting system	Reversibility	Weight	Dimensions mm	Power consumption	Accessories
				Min. / Max.									
	Model		Type	Nm	in lb	giri/1'	r.p.m.	Type	Type	kg	L x Ø	Volt	Drive
STRAIGHT MODELS	E8C1A-1200	111712011		0,3 ÷ 1,6	2,6 ÷ 14,1	590 ÷ 1180	980 / 1180	*		0,78	275x39	32	⊕ F1/4"
	E8C1A-900	111712012		0,3 ÷ 1,6	2,6 ÷ 14,1	435 ÷ 870	740 / 870	*		0,78	275x39	32	⊕ F1/4"
	E8C1A-650	111712013		0,3 ÷ 1,6	2,6 ÷ 14,1	320 ÷ 640	530 / 640	*		0,78	275x39	32	⊕ F1/4"
	E8C2A-2000	111712000		0,6 ÷ 2,5	5,3 ÷ 22,1	1000 ÷ 2000	1650 / 2000	*		0,78	275x39	32	⊕ F1/4"
	E8C3A-1200	111712001		0,6 ÷ 3,0	5,3 ÷ 26,5	590 ÷ 1180	980 / 1180	*		0,78	275x39	32	⊕ F1/4"
	E8C3A-900	111712002		0,6 ÷ 3,5	5,3 ÷ 30,9	435 ÷ 870	740 / 870	*		0,78	275x39	32	⊕ F1/4"
	E8C4A-650	111712003		0,6 ÷ 4,0	5,3 ÷ 35,4	320 ÷ 640	530 / 640	*		0,78	275x39	32	⊕ F1/4"
	E8C5A-350	111712004		0,6 ÷ 4,5	5,3 ÷ 39,8	170 ÷ 340	285 / 340	*		0,78	275x39	32	⊕ F1/4"
MODELS WITH EXTERNAL CLUTCH ADJUSTMENT	E8C1ARE-1200	111712076		0,3 ÷ 1,6	2,6 ÷ 14,1	590 ÷ 1180	980 / 1180	lever start		0,84	275x39	32	⊕ F1/4"
	E8C1ARE-900	111712077		0,3 ÷ 1,6	2,6 ÷ 14,1	435 ÷ 870	740 / 870	lever start		0,84	275x39	32	⊕ F1/4"
	E8C1ARE-650	111712078		0,3 ÷ 1,6	2,6 ÷ 14,1	320 ÷ 640	530 / 640	lever start		0,84	275x39	32	⊕ F1/4"
	E8C2ARE-2000	111712070		0,6 ÷ 2,5	5,3 ÷ 22,1	1000 ÷ 2000	1650 / 2000	lever start		0,84	275x39	32	⊕ F1/4"
	E8C3ARE-1200	111712071		0,6 ÷ 3,0	5,3 ÷ 26,5	590 ÷ 1180	980 / 1180	lever start		0,84	275x39	32	⊕ F1/4"
	E8C3ARE-900	111712072		0,6 ÷ 3,5	5,3 ÷ 30,9	435 ÷ 870	740 / 870	lever start		0,84	275x39	32	⊕ F1/4"
	E8C4ARE-650	111712073		0,6 ÷ 4,0	5,3 ÷ 35,4	320 ÷ 640	530 / 640	lever start		0,84	275x39	32	⊕ F1/4"
	E8C5ARE-350	111712074		0,6 ÷ 4,5	5,3 ÷ 39,8	170 ÷ 340	285 / 340	lever start		0,84	275x39	32	⊕ F1/4"
90° ANGLE MODELS	E8C2A90-2000	111712030		0,6 ÷ 2,5	5,3 ÷ 22,1	1000 ÷ 2000	1650 / 2000	lever start		0,84	327x39	32	□ M1/4"
	E8C3A90-1200	111712031		0,6 ÷ 3,0	5,3 ÷ 26,5	590 ÷ 1180	980 / 1180	lever start		0,84	327x39	32	□ M1/4"
	E8C3A90-900	111712032		0,6 ÷ 3,5	5,3 ÷ 30,9	435 ÷ 870	740 / 870	lever start		0,84	327x39	32	□ M1/4"
	E8C4A90-650	111712033		0,6 ÷ 4,0	5,3 ÷ 35,4	320 ÷ 640	530 / 640	lever start		0,84	327x39	32	□ M1/4"
	E8C5A90-350	111712034		0,6 ÷ 4,5	5,3 ÷ 39,8	170 ÷ 340	285 / 340	lever start		0,84	327x39	32	□ M1/4"
	E8C2A90-2000-BITS	111712040		0,6 ÷ 2,5	5,3 ÷ 22,1	1000 ÷ 2000	1650 / 2000	lever start		0,84	327x39	32	⊕ F1/4" BITS
	E8C3A90-1200-BITS	111712041		0,6 ÷ 3,0	5,3 ÷ 26,5	590 ÷ 1180	980 / 1180	lever start		0,84	327x39	32	⊕ F1/4" BITS
	E8C3A90-900-BITS	111712042		0,6 ÷ 3,5	5,3 ÷ 30,9	435 ÷ 870	740 / 870	lever start		0,84	327x39	32	⊕ F1/4" BITS
	E8C4A90-650-BITS	111712043		0,6 ÷ 4,0	5,3 ÷ 35,4	320 ÷ 640	530 / 640	lever start		0,84	327x39	32	⊕ F1/4" BITS
	E8C5A90-350-BITS	111712044		0,6 ÷ 4,5	5,3 ÷ 39,8	170 ÷ 340	285 / 340	lever start		0,84	327x39	32	⊕ F1/4" BITS
30° ANGLE MODELS	E8C2A30-2000	111712035		0,6 ÷ 2,5	5,3 ÷ 22,1	1000 ÷ 2000	1650 / 2000	lever start		0,84	327x39	32	□ M1/4"
	E8C3A30-1200	111712036		0,6 ÷ 3,0	5,3 ÷ 26,5	590 ÷ 1180	980 / 1180	lever start		0,84	327x39	32	□ M1/4"
	E8C3A30-900	111712037		0,6 ÷ 3,5	5,3 ÷ 30,9	435 ÷ 870	740 / 870	lever start		0,84	327x39	32	□ M1/4"
	E8C4A30-650	111712038		0,6 ÷ 4,0	5,3 ÷ 35,4	320 ÷ 640	530 / 640	lever start		0,84	327x39	32	□ M1/4"
	E8C5A30-350	111712039		0,6 ÷ 4,5	5,3 ÷ 39,8	170 ÷ 340	285 / 340	lever start		0,84	327x39	32	□ M1/4"

Legend

E8C4A-650 = Electric screwdriver with automatic shut off
E = Electric
8 = Power of motor in watt/10
C = Screwdriver

4 = Maximum tightening torque in Nm
A = Torque control with automatic shut off
90 = 90° angle model
30 = 30° angle model

RE = External clutch adjustment
650 = Speed
BITS = female hexagonal output coupling for inserting tools

Legend

Reversibility: all models are suitable for tightening and untightening operation

♦ Tools speed range varies according to the unit used:
 - with **TPU 1** and **TPU 2**, the LOW (slow) speed is approximately equal to 80% of the max speed indicated in the table and can only be set through the LOW/HIGH (slow / fast) speed setting
 - with **TPU-M1**, the speed is adjustable and the minimum speed value is equal to 50% of the max speed, as indicated in the table.

* Starting system: 4 modalities availables for all models

- Lever start
- ↓ Push to start
- +↓ Lever start + push to start
- +↓ Latched lever + push to start

* Accessory drive: female hexagonal drive 1/4", 6,35 mm (ISO 1173).
 * The code number must be used when ordering.

Torque values refer to analysis of laboratory performing tests that comply with the standard ISO 5393 with screwdriver set at to the maximum speed and should be considered as indicative. The values in real applications can be influenced by many factors such as, for example: joint (type of joint, degree of elasticity), screw (type and length), accessory used (type or length of the blade), tightening speed, assembly conditions (free standing screwdriver, screwdriver mounted on a torque arm), operator behavior during the tightening phase.
 For any further details, please address to Fiam Technical Service.

Standard equipment (supplied with the tool)

- Connection cable to power supply unit (code 686903834); lenght 3 mt and with error proof connection system
- Clutch adjustment key (except for models with external adjustment)
- Hanging ring
- Eco-friendly packaging
- Use and maintenance manual.



eTensil screwdrivers, nutrunner motors and TPU power supply units, are covered by an extended warranty of 24 months or 1.000.000 cycles (first goal achieved).

Power supply unit technical features.

Model	Code	Speed	Nr. of connectable tools	Tool feed tension	Feed input	I/O	Visual indicators	Weight kg	L x Width x H mm
TPU 1	686200100	LOW / HIGH (slow / fast)	1	32 VDC	230 Vac \pm 10% 50-60 Hz	-	6 LED	0,6	185 x 150 x 63
TPU 2	686200101	LOW / HIGH (slow / fast)	1	32 VDC	230 Vac \pm 10% 50-60 Hz	5 inputs 5 outputs	6 LED	0,6	185 x 150 x 63

Monitoring unit technical features.

TPU-M1	686200109	Adjustable	1	32 VDC	230 Vac \pm 10% 50-60 Hz	8 inputs 8 outputs	7 LED DISPLAY	0,8	185x150x105
--------	-----------	------------	---	--------	----------------------------	--------------------	---------------	-----	-------------

Standard equipment

- Power supply fitted with cable and European plug
- I/O Connector (only for TPU 2 model)
- Use and maintenance manual
- Eco-friendly packaging.
- The TPU-M1 unit is equipped with adjustable tilt foot.

Accessories available upon request

- **Fixing plate to position** the power supply unit on any surface. It is supplied complete with screws, and can be anchored vertically or on a horizontal support (code 692080000).
- **TPU1 power supply** fitted with cable and American plug (code 686200102).
- **TPU2 power supply** fitted with cable and American plug (code 686200103).
- **TPU-M1 monitoring unit** fitted with cable and American plug (code 686200110).



LED Indicator

3 colours bulb, to be connected to units through 1,5 mt long cable included in supply. It allows the immediate feedback of the tightening process status. It can be fixed to the workbench.

Model	For units	Code
LED Indicator	TPU 2	686990034
LED Indicator	TPU-M1	686990039



Tower-light with audible buzzer

3 colours tower-light, equipped with an audible buzzer to be connected to TPU-M1 monitoring unit through 3 mt long cable included in supply. It allows, with lights and sound signals, the immediate feedback of the tightening process status. Diameter of 55 mm, it can be fixed to the workbench.

Model	For units	Code
Tower-light with audible buzzer	TPU-M1	686990040



SPS (Socket and Program Selector).

Poka Yoke device for selection of fastening program by picking up of sockets/bits, can work together with TPU M1 monitoring unit. It allows the selection of up to 8 sockets or bits (with diameter up to 80 mm) and checks correspondence between socket and pre-set tightening program as indicated from linked controller. Selection LEDS and socket pick-up acoustic signal (buzz): each socket spot is indeed connected to a particular program in the controller so that, when the worker picks one socket the controller is automatically set in accordance.

Available for OPS-Open Program Selection or CPS-Controlled Program Selection.

For further information refer to the catalogue No. 97: SPS - Socket Program Selector.

Model	Code	Unit to use	Dimensions (hxpL) mm	Weight Kg
SPS for TPU M1	687010055	TPU M1	239x310x63	5,8

- For diameters higher than 42 mm, special socket tray:
until 64 mm code 687019016
until 80 mm code 687019022

Accessories.



Screw suction system.

For all eTensil straight screwdrivers and nutrunner motors. Special head (2) to be attached to the tool using the Connection kit (3) and to be connected to the SSU - Vacuum pump. Attached to the head is a special nozzle (1) that can be customized to suit the screws in question or the part to be assembled, which should be submitted to Fiam as a sample. We will also assess the bits (4) to determine the best solution for the screw type.

Model	Code
Screw suction head*	682119050
Connection kit (for screw suction head and screwdriver)	681041036
Connection kit (for screw suction head and nutrunner motor)	681041038
Custom nozzle	upon request
Custom blades	upon request

* supplied with screw suction tube to be connected to the vacuum pump.

SSU - Vacuum pump

Designed and manufactured by Fiam. Necessary for the suction of the screws, it works at 220 Volt-50 Hz with a use of power of only 45 Watts. Supplied with power cable.

Model	L x Width x H mm	Code
SSU - Vacuum pump for screw suction system	210 x 150 x 140	676000120



TOM – Tightening Operation Monitor

Production cycle monitoring unit: it accelerates the cycle time ensuring in-process control of assembled element (for the features see page 4).

To be connected with the TPU2 power unit (code 686200101) with the connection cable code 685001093.

Model	Code	Dimensions (mm)	Electric feed
TOM Monitoring Unit	685001062	208 x 128 x 42	24 V, 110/230V - 50/60 Hz



Multi-dock Connector

code 685001066

Connecting up to 8 tools (each tool has a dedicated program) that can operate individually depending on TOM programming. There are 2 LEDs for each screwdriver: one indicates the enabled screwdriver (to be used) and one indicates the tool is working. Supplied with adapter for connection with TOM and 2 connecting cables.



PISTOL GRIP



AUXILIARY GRIP

Pistol grip

code 681041029

To convert straight models into pistol models.

Auxiliary grip

code 681041030

When using straight screwdrivers at torques higher than 4 Nm, it is good practice to use the auxiliary grip, which reduces the reaction by distributing it over two hands rather than one.



CONNECTION CABLE

Connection cable complete with 90 ° angled fitting

code 686903841

3m-long cable connecting the screwdriver and power supply.

It can be ordered separately and is useful when the screwdriver is transformed from straight to pistol and the power cable drops from above.

Connection cable

code 686903834

The 3m-long cable connecting the screwdriver and power supply unit comes with the screwdriver, though it can also be ordered separately and joined to the cable provided to achieve greater lengths. Please check with the Fiam Technical Advice Department for the maximum length that can be produced.



Multiple connector for I/O

code 692079193

To be connected to the 25-pole I/O ports of Fiam TPU M1 unit. It allows to make the I/O signals available on 3 connectors and therefore the connection with 3 devices in parallel. Equipped with connection cable between unit and multiple connector and relative power supply, it has 8 status LEDs for Outputs and 8 test buttons for Input signals.

Accessories.



Kit Fiam HyperTerminal

code 686200913

Fiam HyperTerminal Kit **allows to connect all Personal Computers** (including those of the latest generation) **so the network systems**, with Fiam units equipped with an RS 232 serial port. For example, by connecting TPU-M1 monitoring unit, it is possible to obtain the tightening results or download the configuration parameters of the set programs, thus allowing data storing to PC.

The kit includes:



USB key containing the HyperTerminal software

The exclusive software designed by Fiam with which it is possible:

- display on the PC text strings received via serial communication
- create both text files and CSV format files for Excel with the collected data
- save the data on the PC for the processing of statistics and analysis on production processes.



Adapter cable

RS232 to USB converter cable, to connect the Unit to the Personal Computer. To use this cable, it is necessary to install the relative Drivers contained in the USB key on the Personal Computer.



NULL Modem adapter

Optional adapter that can be used with other control units produced by Fiam such as shown in the table below.



Gender Changer Serial Adapter

Optional 9-pole "Female Female" type adapter that can be used with the other control units produced by Fiam as shown in the table below.



Serial cable

3 meters long with Male / Female connector to connect the unit directly to devices equipped with an RS 232 port or via the Adapter Cable.

Type of Fiam unit	Adapter cable RS232 to USB	NULL Modem adapter	Gender Changer Adapter
TPU M1, TPU C1-TPU C3 Units	X		
TOM - Monitoring unit	X	X	X

Example screenshot of data coming from serial port

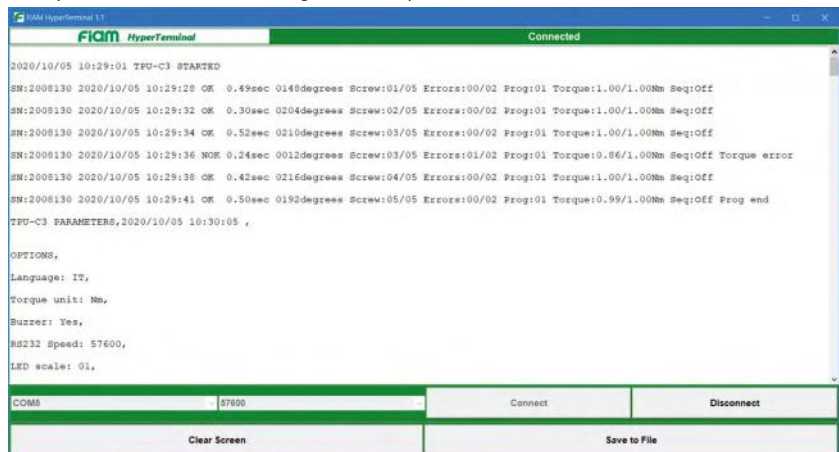

Cartesian and telescopic arms.

These completely counteract the reaction on the operator's hand, the force required to support the tool and the vibrations to the hand-arm system. They make it possible to keep the wrist in a good position with the tool perpendicular to the work point, improving working accuracy and production process quality.



BT-MG magnesium telescopic arms

Telescopic arms in magnesium alloy, designed and produced by Fiam, extremely resistant to mechanical stress thus guaranteeing reliability and long life span, thanks to accurate manufacturing process and applied innovative materials.

Designed with different telescoping extension elements (3 for all models and 2 for BT-MG 10...), they are conform for working areas according to various productive needs. Double terminal coupling guarantees great handiness and maximum freedom of action also for inclined tightening operations. They can be easily installed using a simple plate with reduced dimensions.

Model	Code	Max torque		Max work range	Min work range	Ø max tool
		Nm	in lb	(mm)	(mm)	(mm)
BT-MG 10 800	692071420	10	88.50	650	470	26.5-50
BT-MG 10 1000	692071421	10	88.50	790	540	26.5-50
BT-MG 15 800	692071409	15	132.70	860	505	26.5-50
BT-MG 15 1000	692071401	15	132.70	1070	575	26.5-50
BT-MG 15 1500	692071404	15	132.70	1580	745	26.5-50

Tool holder accessory (1)

code 692079180

Only for eTensil straight models. To install the screwdriver on BT-MG reaction arm. It allows 9 rotation positions of the screwdriver on its own axis.



BCA Articulated cartesian arm

BC and BCA Cartesian arms

Cartesian arms fundamental solutions for ergonomics workplace, designed and manufactured by Fiam, can be used with any type of tool with a diameter up to 50 mm and weight up to 11 kg.

• Cartesian arms

• Articulated cartesian arms

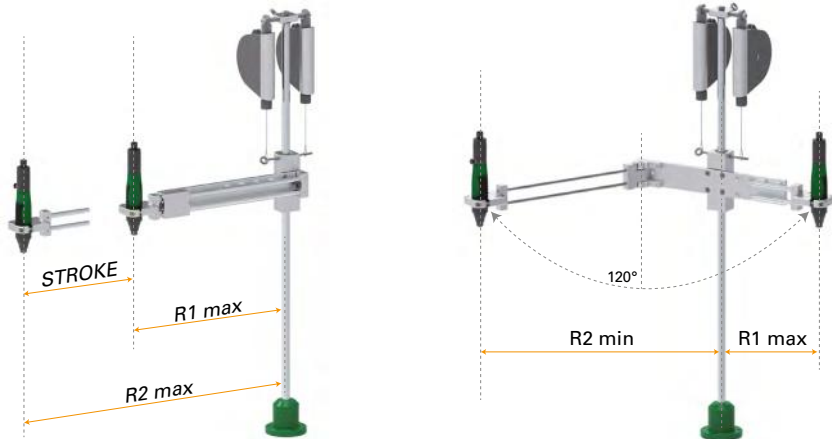

BCA-TOP Articulated cartesian arm

Model	Code	Max torque		Max work range R1	Min work range R2
		(Nm)	(in lb)	(mm)	(mm)
BC5 Cartesian arm	692031030	5	44,2	285-445	600-760
BC12 Cartesian arm	692031031	12	106,8	285-445	600-760
BCA5 Articulated cartesian arm	692031034	5	44,2	110-260	610-730
BCA12 Articulated cartesian arm	692031035	12	106,8	110-260	610-730
BC5-TOP Articulated cartesian arm	692031065	5	44,2	285-445	600-760
BC12-TOP Articulated cartesian arm	692031076	12	106,8	285-445	600-760
BCA5-TOP Articulated cartesian arm	692031067	5	44,2	110-260	610-730
BCA12-TOP Articulated cartesian arm	692031068	12	106,8	110-260	610-730

Tool holder accessories

code 692039108 (2)

For anchoring the straight screwdrivers to the Cartesian arm without damaging it or compromising its operation. Complete with assembly screws.

This accessory cannot be used with RE version eTensil screwdrivers (with external clutch adjustment).

code 681041034 (3)

An accessory for anchoring the top of the straight screwdriver to the Cartesian arm for a better view of the tightening point. Complete with assembly screws.

code 692039233 (4)

Universal clamp suitable to work on vertical or inclined surfaces using tools with pistol grip or angled heads. It promotes a good hand-arm system position by rotating around two axes. It cannot be used with BC25PK/BC40LK arms (see pagg. 27 and 39). For the best installation it can be combined with the accessory cod. 692039108 (ref. 2). Complete with assembly screws.

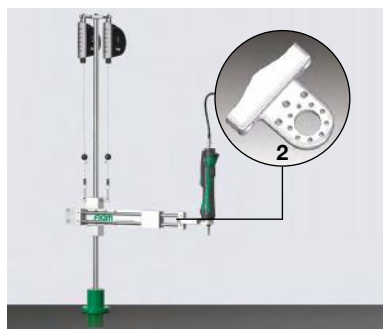

Several accessories to aid operation with the best ergonomics are availables (see [Accessories Catalogue no. 79](#)).

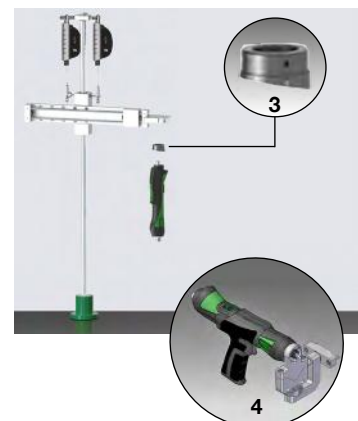



Arms with position monitoring device

All Fiam arms can be fitted with a **position monitoring device** and, **combined with the TPM monitoring unit**, help make tightening systems very suitable for "Poka-Yoke" processes, while increasing the efficiency and speed of the production cycle

There are two types:

- B... TMP1 arms, models with **single angle** movement detection
- B...TPM2 arms, which also measure the **linear** movement of the arm in addition to its **angular** movement.

The arms must be integrated with the TPM monitoring unit code 692078019.

The guided positioning system operates as follows:

- It locates the screwdriver position at the various tightening points and stores them (up to 35 positions/ program and up to 8 programs)
- The screwdriver is enabled when it is at the first stored position (the TPM display shows POS-OK and the POS-OK LED on the telescopic arm lights)
- Each time a screw is tightened, the REMAIN display shows how many screws are left, indicating that it is ready to pass on to the next screw
- The END signal comes on when the stored cycle is complete, and gives the OK to proceed with a new work cycle
- The memorization process takes place by "self-learning": it is sufficient to carry out a work cycle and at each tightening the system stores the position realized and the number of screws
- During the memorization process, a precision tolerance can be programmed within the range: for example, for a length of 1 mm \pm 10% approximately; for the angle 0.1 degrees (maximum tolerances).

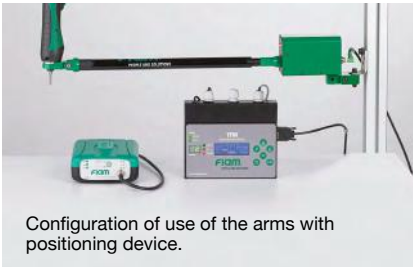

Configuration of use of the arms with positioning device.



Cartesian arm with a position monitoring device.

Model	Code	Max torque Nm	Max torque in lb	Max work range (mm)	Min work range (mm)
Models with SINGLE ANGLE movement detection					
BT-MG 15 800 - TPM1	692071425	15	132,70	985	630
BT-MG 15 1000 - TPM1	692071426	15	132,70	1195	700
BT-MG 15 1500 - TPM1	692071427	15	132,70	1705	870
BC5 -TPM1	692031046	5	44,20	285-445	600-760
BC12-TPM1	692031047	12	106,80	285-445	600-760
Models with ANGLE and LINEAR movement detection					
BT-MG 15 800 - TPM2	692071422	15	132,70	985	630
BT-MG 15 1000 - TPM2	692071412	15	132,70	1195	700
BT-MG 15 1500 - TPM2	692071415	15	132,70	1705	870
BC5 -TPM2	692031042	5	44,20	285-445	600-760
BCA5 -TPM2	692031050	5	44,20	110-260	610-730
BCA12-TPM2	692031051	12	106,80	110-260	610-730

The BCA Cartesian arms are arranged only with the TPM2 device being configured to monitoring the angular and linear positions.



TPM - Tightening Position Monitor

Tightening position monitoring unit, to be used in conjunction with the chosen arm, solely in addition to the TPU 2 power supply (code 686200101) and connection cable (code 692079185).

- Length accuracy (mm): 1 \pm 10%
- Angle accuracy (degrees): 0,1°
- Maximum number of screws per program: 35
- Number of programs: 8
- Total number of screws: 280 (35 per program, 8 programs).

Model	Code	Dimensions (mm)	Electric feed
TPM - Monitoring Unit	692078019	208 x 128 x 42	24 V, 110/230V - 50/60 Hz



Cartesian Arm BC25PK with Automatic downward pushing device.

An extraordinary aid to operators **who can take advantage of its automatic down pressure** and hence **perform tightening without having to apply pressure themselves**. **Pneumatic down pressure** can be set to suit the type of screw used by means of the practical control, which has an indicator showing working pressure.

While returning up after tightening, the arm **automatically returns to the rest position**.

Model	Code	Max torque Nm	Max torque in lb	Max charge (kg)	Push (kg)
BC25PK	692031054	25	221	4	3 ÷ 9

Suitable only for models with lever starting mode (straight and external clutch adjustment screwdrivers).

Tightening automation. Putting the innovation into productivity.

The eTensil series nutrunner motors. Innovation in automatic production processes draws on over 70 years' specialist knowledge of the ins and outs of the industrial tightening process in its every form. A solid, exclusive foundation on which Fiam has built the new eTensil electric nutrunner motors.

In addition to the eTensil motors, we also **design and manufacture all our industrial automation components entirely in-house.** The embodiment of our strict design standards and manufacturing excellence.

Electric solutions for taking the efficiency of tightening process automation to the next level: eTensil was devised as a proudly Italian response to the industry 4.0 demand for green work tools, offering high levels of performance and reliability, smart tools designed **to fit seamlessly into any smart manufacturing operation.**

1. Torque control system with mechanical clutch.

This control system is vital to **tightening torque**, as it automatically cuts off the power supply. This ensures **high repeatability** - in other words a low Mean Shift value - **even when faced with a variable joint softness level.** Values remain unchanged over **million of cycles**, guaranteeing high quality that is consistent over time.

2. On board electronics.

FIAM has designed and created an **innovative on board electronics.** As a result the system is easier to use, workplace layout is tidier, and data exchange between the nutrunner motor and the power unit is faster.

3. Safe mechanical clutch control.

A **protective device** controls access to the mechanical clutch, ensuring adjustments are made safely. This **keeps tightening torque repeatability consistent** and tightening precise and safe, so as to adhere to the highest manufacturing quality standards.

4. Latest generation brushless motor

Brushless motors are the avant-garde in efficient and consistent performance, due to their **high-precision mechanics.** eTensil has been designed in order to obtain endless electric lifespan, thanks to the implementation of low wearing components, to low motor inertia and to a lower heating of the assembly. Hall sensors allow the user to **have full control of rotation** and ironless systems **make the motor so light.**



5. Reduction assembly.

Increased performance in output, **duration and noise level are the principles** that guide the latest designs in gear assembly - aims we have achieved through research focused on ensuring gear lifespan and efficiency as well as the careful sizing and the incorporation of treatment options into the manufacturing cycle. **Such innovative** ways of working mean the gear assembly remains practically **unchanged** even after **thousands of operational hours**, as our lab tests prove.

6. Modular structure.

Functionalities integrated into the circuit board, reduced and simplified electrical connections, its clean design, the modularity and the seamless integration of electronic components into the mechanics; all bases of the constructive **strength, designed to last and guarantee safe** and efficient servicing.

7. Connection cable nutrunner motor - power supply.

The cable is **extremely flexible**, with **sturdy connectors**, designed to last over time and made entirely in Italy upon Fiam's specifications. Standard length is 3 metres, which can be increased by adding additional cables. **Extremely resilient**, flame resistant and hallogen-free, designed to resist oils and to face extreme conditions of use in an industrial environment.

8. Construction you can rely on.

eTensil electric nutrunner motors are not just regular screwdrivers adapted to be installed on a machine: instead, they are **solutions specifically designed to be used in the industrial automation arena**. **They have features** that make them ideal for automation:

- **strong thrust bearings:** to withstand the thrust of the sort of slides found in automated production cycles that move in rapid, non-stop strokes
- **ideal external geometries:** to make machine mounting practical along the full length of the aluminium outer body
- **centring system** designed to achieve unbeatable reliability along both the vertical and horizontal axis.

Automatic screwdrivers. Productivity is within your reach.

The eTensil nutrunner motors have been designed for use also on manually operated automatic tightening systems too. Essential **when tackling tightening jobs with medium and large runs of identical screws**, they are great for speeding up the production cycle with their continuous supply of **screws that are automatically sent to the tightening point**. **Using systems like these, which interconnect with management systems of smart factories (INDUSTRY 4.0), does away with the manual stages** of picking up the screw and positioning it on the bit or on the part, with a 30%-plus reduction in cycle times. Available in various versions, providing the best possible solution for each production scenario.

9. EasyDriver screw feeders.

They manage the entire working cycle with great flexibility because they manage the tightening sequences quickly and easily, customizing them to the specific applications. They are all equipped with

- **Integrated PLC** to manage all machine parameters
- **Modbus TCP/IP** protocol
- EDML software, **Websvrer interface** for remote connection to tightening system.

More models available:

- to feed large screws
- to manage high production rates and have greater working autonomy
- models with dual circular bowls to process **2 geometrically similar** screws, for example differing in length or made from different materials
- with soundproofing devices.

10. Forward bit stroke device.

The eTensil nutrunner motor can be used in conjunction with the forward bit stroke device designed, manufactured and patented by Fiam. It allows the **bit to advance automatically** during the tightening stage, thus reducing operator fatigue, at the same time ensuring the screw is visible at all times and not allowing the bit to pull back. In addition, the screwdriver's head does not rest on the surfaces, protecting them from any potentially damaging contact. The **forward bit stroke** device is recommended for **effortless tightening** even thanks to the thrust of over 25 kg exerted by the blade that ensures reliable tightening on any type of joint and allows to work without the bit moving backs, even for example in the case of self-drilling screws. Tightening strokes can be chosen within the wide range of 100 mm and allow you to tighten in very **right spaces, up against walls or inside small or very deep holes.**

11. Telescopic device.

The **telescopic device** allows you to reach tightening points up against walls, in awkward spaces or inside holes. The various telescopic stroke options are: 40, 60 and 100 mm. The device's mechanics, as well as offering great smoothness of telescopic shaft, is equipped with a double sensor:

- **rest sensor:** always active, monitoring the head's stroke, it does not allow the screw to be called while tightening is still in progress. This benefits productivity as it stops screws jamming. The cycle stops when the set tightening torque is reached.
- **depth control sensor:** by measuring the tightening stroke, it allows the cycle to be stopped once screw height reaches the preset height.

12. Tightening heads.

The screw-retaining heads used mechanically hold the screw from the feeder and guide it correctly and safely to allow the bit to descend to the screw and tighten it onto the component. Since they are essential for reliable tightening, they are full customized by Fiam, based on the know-how gained over the years.

Their benefits:

- **excellent screw holding**
- **perfect screw driving at the tightening point**
- **thanks to customized design, heads can process various screws sizes, even in embedded spots**
- **quick and easy assembly and disassembly.**

For further information refer to the catalogue No. 89: [CA-automatic screw feeding system](#).



MCA tightening modules.

They can be integrated anywhere.

MCA tightening modules with eTensil nutrunner motors are packed with innovation ready to make any production process even faster and more reliable. Solutions that are ready and tested for **integration into existent production lay out and which relate to the management systems of production plant (Industry 4.0) and can be managed remotely to increase reliability**, as well the quality of the tightening process and therefore of the end product.

13. All the benefits of MCA modules.

MCA modules comprise:

- eTensil nutrunner motors
- fastening slide
- screw-retaining head
- screw feeding system.

With MCA modules:

- **screws are sent continuously and quickly** from the bowl feeder to the screw-retaining device
- the **approach** and subsequent **tightening** of the screw on the component is **automatic** and accurate
- the whole tightening cycle is **controlled and monitored by an integrated PLC** that interfaces with the automated production systems (Industry 4.0)

- the **resulting tightening cycles are** complete and autonomous, with a simple external start
- the fastening slides ensure a **precise approach stroke of the nutrunner motor/screw-retaining head to the component**, and are ideal to working even from the **bottom to the top and/or for layouts with reduced encumbrements**. Light and compact they can also withstand substantial axial thrust (e.g. assembly with self-drilling screws) and can be supplied with “Screw at sight” function to facilitate screw engagement movement before steps of approach and subsequent tightening.

- the EasyDriver screw feeders **manage the entire working cycle** with great flexibility: they control the tightening sequences quickly and easily, customizing them to the specific applications. They are all equipped with
- **Integrated PLC** to manage all machine parameters
- **Modbus TCP/IP** protocol
- EDMI software, **Websvrer interface** for remote connection to tightening system
- Many sensors and devices designed to eliminate any possible downtime.

14. Versatile any- where.

Ideal for:

- assembly lines
- turntables
- manipulators
- electric cartesian axes x,y,z: in order to tighten at different working heights
- robots
- cobots.

For further information refer to the catalogue No. 73: [MCA-Tightening module to be integrated into automatic production systems.](#)



Fiam

PEOPLE AND SOLUTIONS

EasyDriver

www.fiamgroup.com

ON/OFF switch

Vibration adjustment

Fiam

PEOPLE AND SOLUTIONS

www.fiamgroup.com

Tighten with Cobots.

Humans take a leading role.

There will be a **growing use** of “smart machines”, or **collaborative robots**, in production systems. These solutions are not destined to replace humans, but to collaborate with them and **free them from the heavier and more dangerous tasks, allowing them to provide the real added value in their work**. Operators, or humans, become the ideal means for carrying out complex operations, and their **skills are extended** through a process of “*job enlargement*”, in which they are asked to **perform the more critical tasks** so that their daily work is more motivating and their jobs are more highly qualified.

15. The MCA module for Cobots.

These tightening modules with automatic screw feeding pair perfectly with all collaborative robots on the market.

There is a growing use of smaller cobots on assembly lines as they are ideal for:

- **automating repetitive operations and making the best use of the operators' skills**
- **carrying out most tightening jobs automatically**
- **being quickly reprogrammed and used for different applications.**

Ease of programming and very fast setup.

16. EasyDriver screw feeders.

In addition to relating to the line PLC and the control unit of the nutrunner motor, the available screw feeders are equipped with **Modbus TCP/IP communication** protocol, that enables broader and faster communication - via Ethernet connection - of all work-cycle-related information and digital Input and Output signals exchanged with and sent to the Cobot. It enables the Cobot to change the feeder's operating parameters. Moreover, specific sensors check whether the screw has dropped into the hose properly and ready it for subsequent shooting: this avoids screws jamming and building up in the screw shooting hose and ensures uninterrupted work.

17. Forward bit stroke device.

Designed to be fixed to the cobot's wrist, this device **allows the bit to advance to the tightening point automatically** and not allows it to withdraw. During the tightening stage, the screwdriver's head does not rest on the surfaces, protecting them from any potentially damaging contact. The device houses an eTensil nutrunner motor.

18. Safe.

Since the auto-advance device requires hardly any thrust for tightening, this system is **perfectly in line with safety requirements**. In addition, the screw is **always held inside jaws** and it is only shot out once the **screwdriver head is positioned by the cobot over the tightening point**: this means that the tip of the screw is never exposed during handling and hence cannot hit the operator.

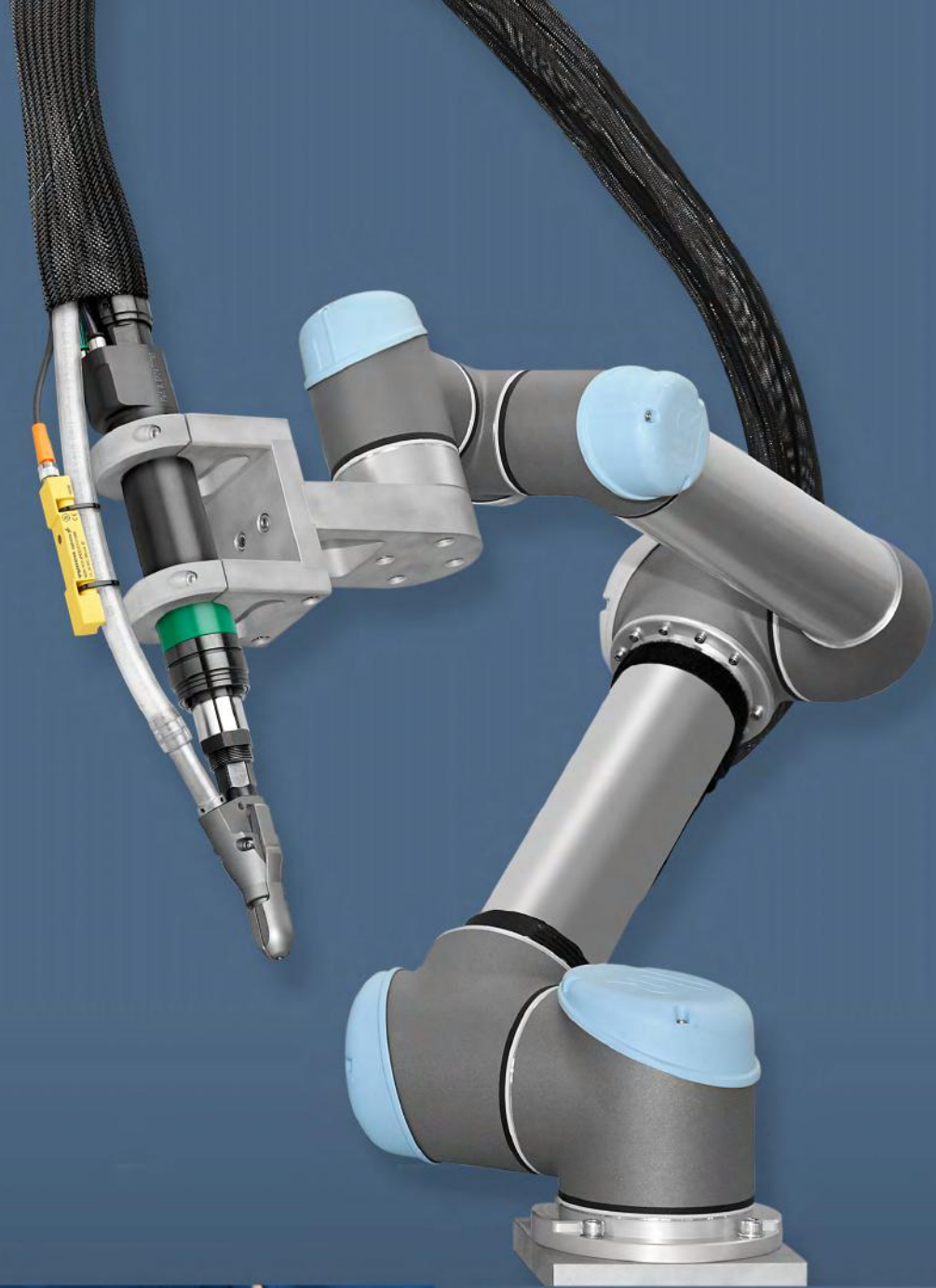

Nutrunner motors technical features.

Type of nutrunner motor	Code	Tightening torque		*Idle speed range with TPU M1	*Idle speed slow-L / fast-H with TPU1 and TPU2	Reversibility	Weight	Accessories	Dimensions L x Ø
		Min. / Max.		r.p.m.	r.p.m.				
Model	Code	Nm	in lb	r.p.m.	r.p.m.	Type	kg	Drive	mm
E8MC1A-1200	111712706	0,3 ÷ 1,6	2,6 ÷ 14,1	590 ÷ 1180	980 / 1180		0,87	⊕ F1/4"	295x36
E8MC1A-900	111712707	0,3 ÷ 1,6	2,6 ÷ 14,1	435 ÷ 870	740 / 870		0,87	⊕ F1/4"	295x36
E8MC1A-650	111712708	0,3 ÷ 1,6	2,6 ÷ 14,1	320 ÷ 640	530 / 640		0,87	⊕ F1/4"	295x36
E8MC2A-2000	111712700	0,6 ÷ 2,5	5,3 ÷ 22,1	1000 ÷ 2000	1650 / 2000		0,87	⊕ F1/4"	295x36
E8MC3A-1200	111712701	0,6 ÷ 3	5,3 ÷ 26,5	590 ÷ 1180	980 / 1180		0,87	⊕ F1/4"	295x36
E8MC3A-900	111712702	0,6 ÷ 3,5	5,3 ÷ 31,0	435 ÷ 870	740 / 870		0,87	⊕ F1/4"	295x36
E8MC4A-650	111712703	0,6 ÷ 4	5,3 ÷ 35,4	320 ÷ 640	530 / 640		0,87	⊕ F1/4"	295x36
E8MC5A-350	111712704	0,6 ÷ 4,5	5,3 ÷ 39,8	170 ÷ 340	285 / 340		0,87	⊕ F1/4"	295x36

Legend

E8MC4A-650 = Electric nutrunner motor with automatic shut off
E = Electric

8 = Power of motor in watt/10
MC = Screwdriver
4 = Maximum tightening torque in Nm

A = Torque control with automatic shut off
650 = Speed.

Legend

Reversibility: all models are suitable for tightening and untightening operation

- Tools speed range varies according to the unit used:
 - with **TPU 1** and **TPU 2**, the LOW (slow) speed is approximately equal to 80% of the max speed indicated in the table and can only be set through the LOW/HIGH (slow / fast) speed setting. For untightening operations, only HIGH speed is available with these units, i.e. the speed cannot be modified. For this type of requirement, TPU-M1 unit should be used.
 - with **TPU-M1**, the speed is instead adjustable and the minimum speed value is equal to 50% of the max speed, as indicated in the table.

Starting system

Remote start

- Accessory drive: female hexagonal drive 1/4", 6,35 mm (ISO 1173).
- The code number must be used when ordering.

Torque values refer to analysis of laboratory performing tests that comply with the standard ISO 5393 with screwdriver set at to the maximum speed and should be considered as indicative. The values in real applications can be influenced by many factors such as, for example: joint (type of joint, degree of elasticity), screw (type and length), accessory used (type or length of the blade), tightening speed, assembly conditions (free standing screwdriver, screwdriver mounted on a torque arm), operator behavior during the tightening phase. For any further details, please address to Fiam Technical Service.

Standard equipment (supplied with the nutrunner motor)

- Connection cable to power supply unit (code 686903834); lenght 3 mt and with error proof connection system
- Clutch adjustment key
- Eco-friendly packaging
- Use and maintenance manual.

Models and accessories available upon request

- Motors with axial compensator 1/4" drive (code 680601090), 3/8" drive (code 680601070), 1/4" quick change chuck (code 680601080)
- Motors with off-set device (for narrow distances between the axis) - code 680601185
- Motors with off-set device with axial compensator - code 680601190
- To use the offset device, you must order the adapter - code 687029248
- Fixing flange 36 mm in diameter - code 684011007
- Motors with modified flange and / or with customized body design
- Motors with angled head

Power supply unit technical features.

Model	Code	Speed	Nr. of connectable tools	Tool feed tension	Feed input	I/O	Visual indicators	Weight kg	L x Width x H mm
TPU 2	686200101	LOW / HIGH (slow / fast)	1	32 VDC	230 Vac ±10% 50-60 Hz	5 inputs 5 outputs	6 LED	0,6	185x150x63

Monitoring unit technical features.

TPU-M1	686200109	Adjustable	1	32 VDC	230 Vac ±10% 50-60 Hz	8 inputs 8 outputs	7 LED DISPLAY	0,8	185x150x105
--------	-----------	------------	---	--------	-----------------------	-----------------------	---------------	-----	-------------

Standard equipment

- Power supply fitted with cable and European plug
- I/O Connector (only for TPU 2 model)

- Use and maintenance manual
- Eco-friendly packaging.

- The TPU-M1 unit is equipped with adjustable tilt foot.

Accessories available upon request

Signal lights and various accessories for power supplies and monitoring unit: see p. 23
 Fiam HyperTerminal kit to manage tightening results: see p. 25.



Tensil screwdrivers, nutrunner motors and TPU power supply units, are covered by an extended warranty of 24 months or 1.000.000 cycles (first goal achieved).

Dimensions.

Electric nutrunner motor.

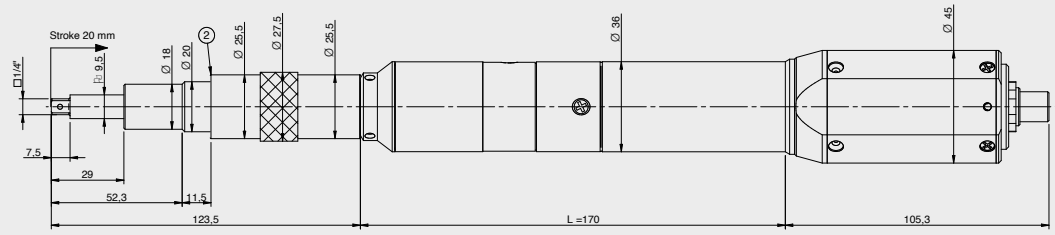

Square drive axial compensator □ 1/4" (Din 3121-F 6,3) - code 680601090

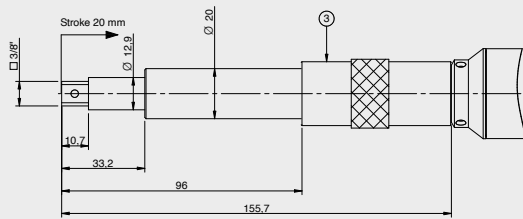

Square drive axial compensator
□ 3/8" (Din 3121-F 10) - code 680601070

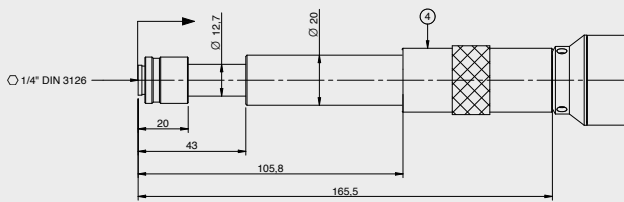

Axial compensator with 1/4" hex. □ quick change chuck (Din 3126-F 6,3) - code 680601080

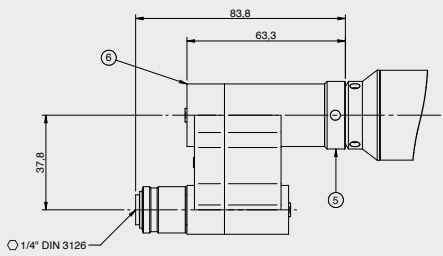



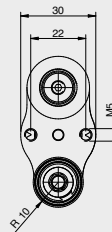
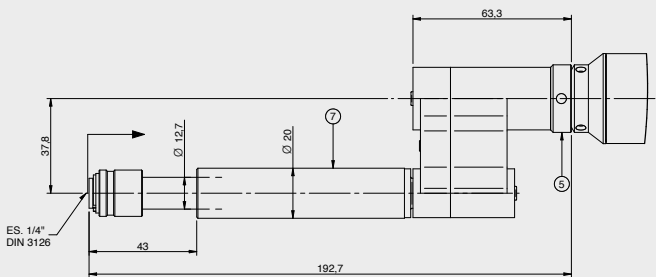





Offset device for very small centre-to-centre distances
code 680601185







Offset device with axial compensator
code 680601190

CA handheld tightening system: auto feed screwdrivers technical features.

	Type of screwdriver	Grip	Tightening torque of eTensil nutrunner motor used Min. / Max.		* Idle speed Min. / Max.	Starting system	Reversibility	Power supply / Monitoring unit	Type of Screw Feeder combinable
	Model	Type	Nm	in lb	r.p.m.	Type	Type		
AUTO-ADVANCE DEVICE	CA E8MC D AA U2/M1...		0,3 ÷ 4,5	2,6 ÷ 39,8	285 ÷ 2000	Lever start		TPU 2 TPU-M1	ED B ED B 1 1 ED B M 1 1 ED B 2 1
	CA E8MC PA AA U2/M1...		0,3 ÷ 4,5	2,6 ÷ 39,8	285 ÷ 2000	Push button		TPU 2 TPU-M1	ED B ED B 1 1 ED B M 1 1 ED B 2 1
TELESCOPIC DEVICE	CA E8MC D TE U2/M1...		0,3 ÷ 4,5	2,6 ÷ 39,8	285 ÷ 2000	Push start		TPU 2 TPU-M1	ED B ED B 1 1 ED B M 1 1 ED B 2 1
	CA E8MC PA TE U2/M1...		0,3 ÷ 4,5	2,6 ÷ 39,8	285 ÷ 2000	Push start		TPU 2 TPU-M1	ED B ED B 1 1 ED B M 1 1 ED B 2 1

Legend	
	Non-reversible screwdriver (only tightening) The telescopic model provides also tightening on screws with left thread
Tightening system	CA
Type of screwdriver	E8MC Electric technology eTensil
Type of grip	D Straight P Pistol PA Forward pistol AA Forward bit stroke device
Tightening device	TE Telescopic device
Type of control units	U2 = TPU 2 - Power supply unit eTensil M1 = TPU-M1 - Monitoring unit eTensil
Type of screw feeder	B = Easy Driver ED B B11 = Easy Driver ED B 1 1 BM11 = Easy Driver ED B M 1 1 B21 = Easy Driver ED B 2 1

Starting system	
	Lever start
	Push button
	Push start
	Push start

* Accessory drive: female hexagonal drive 1/4", 6,35 mm (ISO 1173).

Torque values refer to analysis of laboratory performing tests that comply with the standard ISO 5393 with screwdriver set at to the maximum speed and should be considered as indicative. The values in real applications can be influenced by many factors such as, for example: joint (type of joint, degree of elasticity), screw (type and length), accessory used (type or length of the blade), tightening speed, assembly conditions (free standing screwdriver, screwdriver mounted on a torque arm), operator behavior during the tightening phase. For any further details, please address to Fiam Technical Service.

* Tools speed range varies according to the unit used:
 - with **TPU 2**, the LOW (slow) speed is approximately equal to 80% of the max speed indicated in the table and can only be set through the LOW/HIGH (slow/fast) speed setting
 - with **TPU-M1**, the speed is adjustable and the minimum speed value is equal to 50% of the max speed, as indicated in the table.

Standard equipment (supplied with CA handheld tightening system)

- Electric auto feed screwdriver
- EasyDriver feeder chosen
- Power supply unit TPU 2 or TPU-M1 monitoring unit
- Connection cables
- Clutch adjustment key
- Ethernet connection cable
- Screw-retaining head customized for the screw, completed with bush
- 4 tightening bits (1 fitted + 3 spares)
- Extension for spare blade
- Screw shooting hose
- Shielded screw transit sensor (only for screwdrivers with forward bit stroke device)
- Hanging ring
- Operation and maintenance manual
- Eco-friendly packaging, dimensions mm: L 600 x 450 x h 520

Power supply unit technical features.

Model	Code	Speed	Nr. of connectable tools	Tool feed tension	Feed input	I/O	Visual indicators	Weight kg	L x Width x H mm
TPU 2	686200101	LOW / HIGH (slow / fast)	1	32 VDC	230 Vac ±10% 50-60 Hz	5 inputs 5 outputs	6 LED	0,6	185x150x63

Monitoring unit technical features.

TPU-M1	686200109	Adjustable	1	32 VDC	230 Vac ±10% 50-60 Hz	8 inputs 8 outputs	7 LED DISPLAY	0,8	185x150x105
--------	-----------	------------	---	--------	--------------------------	-----------------------	------------------	-----	-------------

- Standard equipment**
- Power supply fitted with cable and European plug
 - I/O Connector (only for TPU 2 model)
 - Use and maintenance manual
 - Eco-friendly packaging.
 - The TPU-M1 unit is equipped with adjustable tilt foot.

Accessories available upon request

Signal lights and various accessories for power supplies and monitoring unit: see p. 23
 Fiam HyperTerminal kit to manage tightening results: see p. 25.



eTensil screwdrivers, nutrunner motors and TPU power supply units, are covered by an extended warranty of 24 months or 1.000.000 cycles (first goal achieved).



EasyDriver screw feeders for autofeed screwdrivers.

Feeders that can be used with CA auto feed screwdrivers are of different types:

EasyDriver ED B (1 x 240mm Ø bowl feeds 1 screwdriver)

Feeds the screws optimally and without jamming. For screws between 10 and 35 mm in length.

EasyDriver ED B 1|1 (1 x 240mm Ø bowl feeds 1 screwdriver).

Feeds the screws optimally and without jamming and used when greater soundproofing is required. For screws between 10 and 35 mm in length.

EasyDriver ED B MAXI 1|1 (MAXI 1|1 = 420mm Ø bowl feeds 1 screwdriver).

Used when the job involves large screws and also in the event of high production rates to allow the system to run unaided for longer. For screws between 35 and 60 mm in length.

EasyDriver ED B 2|1 (2|1 = 2 240mm Ø bowls feed 1 screwdriver).

With its dual circular bowls, it can process 2 geometrically similar screws, for example differing in length or made from different materials (e.g. stainless steel / browned steel) to feed a slide (one way). Screw choice is managed by a dedicated input. For screws between 10 and 35 mm in length.

For more information about the features refer to the catalogue No. 89:

[CA - Handheld tightening system with automatic screw feeding.](#)



Screw-retaining heads (nose piece).

They are completely customized to the customer's needs. Available with:

- **With anti-overturning device** for screws with length/head diameter ratio between 1.1 (approx.) and 1.5, To prevent screw jamming
- **With friction jaws** holding the screw on the head and not on the stem: jaws do not open, allowing screw insertion into holes
- **For big screws** to tighten screws up to 45 mm length
- **With hose** to reach embedded tightening points or inside holes
- **With support or protective spacer/special materials** to ease the positioning on the components and to avoid damaging them during assembly
- **With elastic hose and mechanical screw gripping.** Ensures the screw is held perfectly every time.

For more information about the features refer to the catalogue No. 89:

[CA - Handheld tightening system with automatic screw feeding.](#)



BC40LK cartesian arm. Also with pneumatic locking device.

The BC40 (code 692031033) and BCA40 (code 692031037) Cartesian arms can be used with auto-feeding screwdrivers. The BC40LK model is specifically for use with auto-feeding screwdrivers with auto-advance, which provide an automatic pushing force on the workpiece to aid operators so that they do not have to apply force while tightening.

With this Cartesian arm, in addition to all the benefits offered by Fiam Cartesian arms (see page 24), operators can also profit from a **special device that counteracts the "recoil" caused by the tool bit during tightening** and redirects this force to the mechanical arm rather than that of the operator. When there is no power supply, the system stops automatically to prevent the pneumatic device from slipping and avoid any risk of crushing and/or accidental movement.

It can also be used in conjunction with the auxiliary grip to prevent incongruous hand-arm system positions (code 692039237 - see [Accessories Catalogue no. 79](#)).

Model	Code	Max torque (Nm)	Max charge (Kg)
BC40LK	692031055	40	5
BC40	692031033	40	2
BCA40	692031037	40	2



Ergonomic grip.

To use with screwdrivers installed on BC and BCA Cartesian Arms.

It allows correct gripping at any point in which the arm can operate, preventing incongruous handarm system positions.

The grip can be installed on the right or left of the boom, with vertical or horizontal gripping.

In all these positions, **the grip turns around its axis or can be locked, depending on how it needs to be used.**

It has a housing for the screwdriver connector as well as a lever to load and shoot screws.

Model	Code
Grip for auto feed screwdrivers	692039237



Supporting structures and hoppers.

Entirely designed and manufactured by Fiam, they serve to support EasyDriver feeders and their hoppers when used to meet the need for fast production rhythms. They ensure greater cleanliness and functionality of the operational layout, thanks to:

- An **aluminium base plate complete with holes** for fastening to the feeder
- **Hollow aluminium profiles that allow cables and tube bundles to pass** under the supporting surface
- **Supporting feet with adjustable height** and the option of anchoring to the floor simply with the brackets provided.

Discover the available configurations on page. 43

For more information about the features refer to the catalogue No. 89:

[CA - Handheld tightening system with automatic screw feeding.](#)

MCA tightening modules: technical specifications.

	Type of nutrunner	Torque range of nutrunner motor eTensil		*Idle speed range	Type of EasyDriver screw feeder	Type of fastening slide model
	Model	Min. / Max.	Min. / Max.	Min. / Max.	Model	
WITH FASTENING SLIDE	MCA E8MC S.../D... U2/M1...	0,3 ÷ 4,5	2,6 ÷ 39,8	285 ÷ 2000	ED B ED B 1 1 ED B M 1 1 ED B 2 1 ED B 1 2 ED B M 1 2	SM SW DM DW
						Forward bit stroke device for Cobot
FOR COBOT	MCA E8MC AC U2/M1...	0,3 ÷ 4,5	2,6 ÷ 39,8	285 ÷ 2000	ED B ED B 1 1 ED B M 1 1 ED B 2 1 ED B 1 2 ED B M 1 2	stroke: 100 mm

Legend	
	Non-reversible nutrunner motor (only tightening)
Tightening module	MCA
Type of nutrunner motor	E8MC Electric technology eTensil
Type of fastening slide	SM Single stroke SW Single stroke with screw at sight DM Dual stroke DW Single stroke with screw at sight
Tightening device	AC Forward bit stroke for Cobot
Type of control units	U2 = TPU 2 - Power supply unit eTensil M1 = TPU-M1 - Monitoring unit eTensil
Type of screw feeders	B = Easy Driver ED B B11 = Easy Driver ED B 1 1 BM11 = Easy Driver ED B M 1 1 B21 = Easy Driver ED B 2 1 B12 = Easy Driver ED B 1 2 BM12 = Easy Driver ED B M 1 2

Starting system
Remote start

* Accessory drive: female hexagonal drive 1/4", 6,35 mm (ISO 1173).

Torque values refer to analysis of laboratory performing tests that comply with the standard ISO 5393 with screwdriver set at to the maximum speed and should be considered as indicative. The values in real applications can be influenced by many factors such as, for example: joint (type of joint, degree of elasticity), screw (type and length), accessory used (type or length of the blade), tightening speed, assembly conditions (free standing screwdriver, screwdriver mounted on a torque arm), operator behavior during the tightening phase. For any further details, please address to Fiam Technical Service.

* Tools speed range varies according to the unit used:
- with TPU 2, the LOW (slow) speed is approximately equal to 80% of the max speed indicated in the table and can only be set through the LOW/HIGH (slow / fast) speed setting
- with TPU-M1, the speed is adjustable and the minimum speed value is equal to 50% of the max speed, as indicated in the table.

Standard equipment (supplied with MCA module with FASTENING SLIDE)

- EasyDriver feeder chosen
- Electric nutrunner motor
- Power supply unit TPU 2 or TPU-M1 monitoring unit with connection cables
- Clutch adjustment key
- 4 tightening bits (1 fitted + 3 spares)
- Ethernet connection cable
- Fastening slide complete with pneumatic fittings and supporting bracket
- Screw-retaining head customized for the screw, completed with bush
- Screw shooting hose
- Two shielded screw transit sensor
- Operation and maintenance manual
- Eco-friendly packaging (weight kg 3)
- Dimensions: mm L 600 x 450 x h 520

Standard equipment (supplied with MCA module for COBOT)

- EasyDriver feeder chosen
- Electric nutrunner motor with forward bit stroke device
- Power supply unit TPU 2 or TPU-M1 monitoring unit with connection cables
- Clutch adjustment key
- 4 tightening bits (1 fitted + 3 spares)
- Ethernet connection cable
- Screw shooting hose
- Two shielded screw transit sensors
- Operation and maintenance manual
- Eco-friendly packaging
- Dimensions: mm L 600 x 450 x h 520

The supply does not include the bracket for fixing the forward bit stroke device to the Cobot.

Power supply unit technical features.

Model	Code	Speed	Nr. of connectable tools	Tool feed tension	Feed input	I/O	Visual indicators	Weight kg	L x Width x H mm
TPU 2	686200101	LOW / HIGH (slow / fast)	1	32 VDC	230 Vac ±10% 50-60 Hz	5 inputs 5 outputs	6 LED	0,6	185x150x63

Monitoring unit technical features.

TPU-M1	686200109	Adjustable	1	32 VDC	230 Vac ±10% 50-60 Hz	8 inputs 8 outputs	7 LED DISPLAY	0,8	185x150x105
--------	-----------	------------	---	--------	--------------------------	-----------------------	------------------	-----	-------------

Standard equipment

- Power supply fitted with cable and European plug
- I/O Connector (only for TPU 2 model)

- Use and maintenance manual
- Eco-friendly packaging.

- The TPU-M1 unit is equipped with adjustable tilt foot.

Accessories available upon request

Signal lights and various accessories for power supplies and monitoring unit: see p. 23
Fiam HyperTerminal kit to manage tightening results: see p. 25.



eTensil screwdrivers, nutrunner motors and TPU power supply units, are covered by an extended warranty of 24 months or 1.000.000 cycles (first goal achieved).

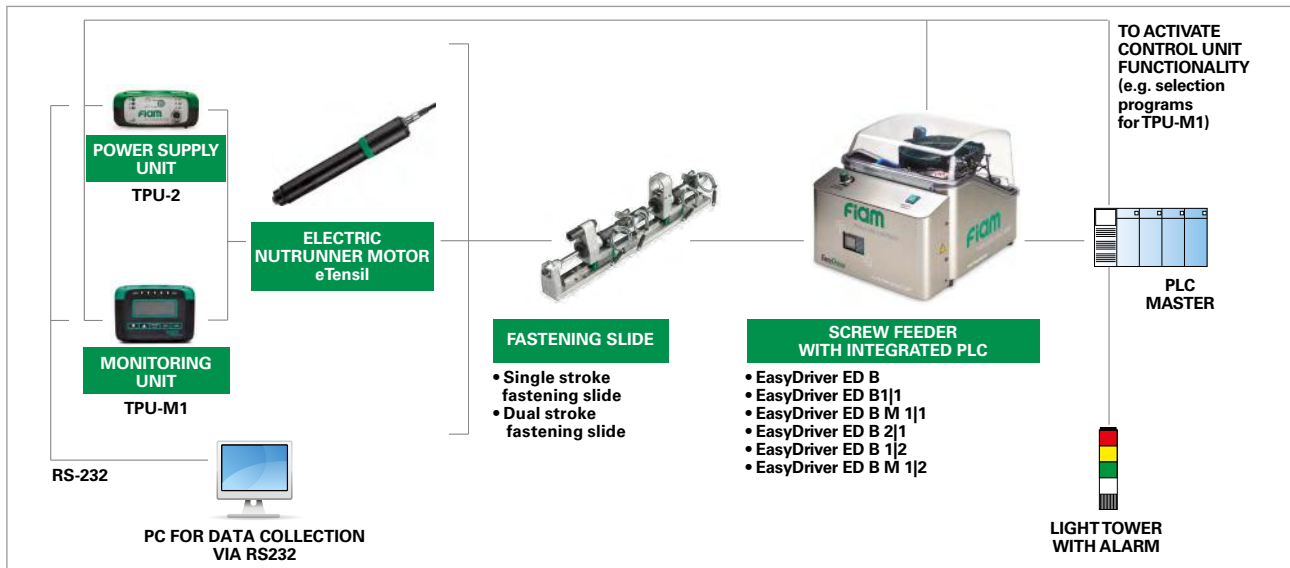

EasyDriver feeders for tightening modules.

Feeders that can be used with MCA modules are of different types:

EasyDriver ED B (1 x 240mm Ø bowl feeds 1 slide/spindle)

Feeds the screws optimally and without jamming.

For screws between 10 and 35 mm in length.

EasyDriver ED B 1|1 (1 x 240mm Ø bowl feeds 1 slide/spindle).

Feeds the screws optimally and without jamming and used when greater soundproofing is required.

For screws between 10 and 35 mm in length.

EasyDriver ED B M 1|1 (MAXI 1|1 = 420mm Ø bowl feeds 1 slide/spindle). Used when the job involves large screws and also in the event of high production rates to allow the system to run unaided for longer. For screws between 35 and 60 mm in length.

EasyDriver ED B 2|1 (2|1 = 2 240mm Ø bowls feed 1 slide/spindle). With its dual circular bowls, it can process 2 geometrically similar screws, for example differing in length or made from different materials (e.g. stainless steel / browned steel) to feed a slide (one way). Screw choice is managed by the feeder's PLC through a selector or by an external signal. For screws between 10 and 35 mm in length.

EasyDriver ED B 1|2 (1 x 240mm Ø bowl feeds 2 slides/spindles). Designed to feed two single- or dual-stroke slides. The work cycle involves selecting and shooting 2 screws at the same time. For screws between 10 and 35 mm in length.

EasyDriver ED B M 1|2 (1 x 420mm Ø bowl feeds 2 slides/spindles). Used when the job involves large screws and there is the need to feed two single- or dual-stroke slides. The work cycle involves selecting and shooting 2 screws at the same time. For screws between 35 and 60 mm in length.

For more information about the features refer to the catalogue No. 73:

MCA-Tightening module to be integrated into automatic production systems.



Fastening slides.

Are **completely designed by Fiam** who also takes care of their construction. They are equipped with:

- **Shielded screw transit sensor** even monitors very small screws
- **Practical and rational hose** that includes cables between slide and feeder
- **Pneumatic cylinders** equipped with built-in air decelerators.

The models available are:

- **SM - SINGLE STROKE**: this fastening slide stands out for the single stroke performed by its motor to reach the tightening point and then tighten. Considering compact dimensions and weight, single stroke fastening slides are particularly suitable in situations where the approach movement is made by a robot arm or a manipulator with Z axis.
- **DM - DUAL STROKE**: in addition to the stroke performed by the motor for the purpose of tightening, they feature an additional approach stroke to bring the head down to the component.
- **DUAL STROKE WITH OFF-SET DEVICE**: in addition to the stroke performed by the motor for the purpose of tightening, these slides feature an additional approach stroke to bring the head down to the component, as well as the offset device, which enables you to reach tightening points with very short centre-to-centre distances.

“Screw at sight” function

Fastening slide can be supplied with this function: the screw is held firmly inside the screw-retaining head and screw engagement movement is achieved by means of an additional cylinder. Once the screw has reached the screw-retaining head, the imprint is engaged and then further steps of approach and subsequent tightening can be completed.

Compact configuration

Ideal for working from the bottom to the top and/or for layouts with reduced encumbrances. The configuration also includes the “screw at sight” function which, in addition to allowing greater ease of centering on the tightening point, if used from the bottom up, prevents the screw from falling back to the end of the shot.

For more information about the features refer to the catalogue No. 73:

MCA-Tightening module to be integrated into automatic production systems.



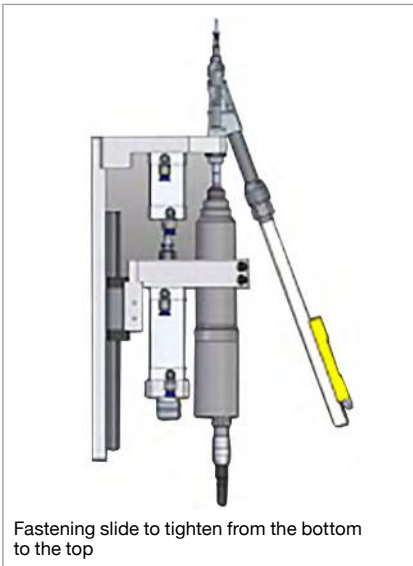

Fastening slide to tighten from the bottom to the top

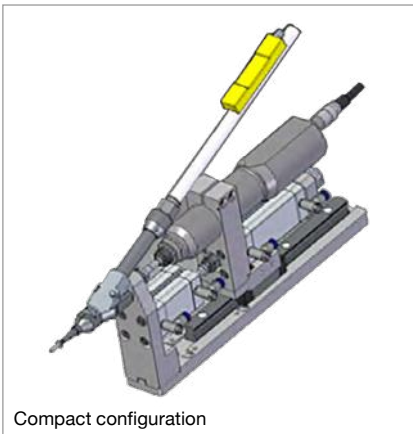

Compact configuration

Single-stroke fastening slide	Size (rail track size)	Tightening and approach strokes	Cylinder Ø (bore)
	mm	mm	mm
SM 15D20 050-00 36	15	50	20
SM 15D20 080-00 36	15	80	20
SM 15D25 050-00 36	15	50	25
SM 15D25 080-00 36	15	80	25

Dual-stroke fastening slide	Size (rail track size)	Tightening and approach strokes	Cylinder Ø (bore)
	mm	mm	mm
DM 15D20 050-50 36	15	50-50	20
DM 15D20 050-80 36	15	50-80	20
DM 15D20 080-50 36	15	80-50	20
DM 15D20 080-80 36	15	80-80	20
DM 15D25 050-50 36	15	50-50	25
DM 15D25 050-80 36	15	50-80	25
DM 15D25 080-50 36	15	80-50	25
DM 15D25 080-80 36	15	80-80	25

How to read model names

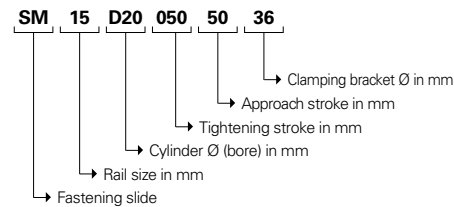

Screw-retaining heads (nose piece).

They are completely customized to the customer's needs. All equipped with a mechanical grip which ensures perfect retention of the screw on the head and represent an excellent alternative to screw suction systems that can become inefficient in the case of assemblies on materials that create dust during tightening. Available with:

- **With anti-overturning device** for screws with length/head diameter ratio between 1.1 (approx.) And 1.5. To prevent screw jamming
- **With friction jaws** holding the screw on the head and not on the stem: jaws do not open, allowing screw insertion into holes
- **For big screws** to tighten screws up to 45 mm length
- **With hose** to reach embedded tightening points or inside holes
- **With support or protective spacer/special materials** to ease the positioning on the components and to avoid damaging them during assembly
- **With elastic hose and mechanical screw gripping.** The hose not only holds the screw perfectly on the head but it rotates together with the screw during tightening. Ideal situation for embedded tightening points.

For more information about the features refer to the catalogue No. 73:

[MCA-Tightening module to be integrated into automatic production systems.](#)



Supporting structures and hoppers.

Entirely designed and manufactured by Fiam, they are useful to support EasyDriver feeders and their hoppers when used to solve needs production at high rates.

They ensure greater cleanliness and functionality of the operational layout thanks to:

- An **aluminum base plate already prepared with the holes** that allow to fix the suitable feeder on it
- **Aluminum profiles with channels for cables and tube bundles inside the slots** positioned under the support surface
- **Support adjustable feet in height** and possibility of having additional brackets for floor fixing through a simple anchoring with supplied squares.

Per approfondire le caratteristiche, consultare il catalogo 73: [MCA - Modulo di avvitatura da integrare su sistemi produttivi automatici.](#)

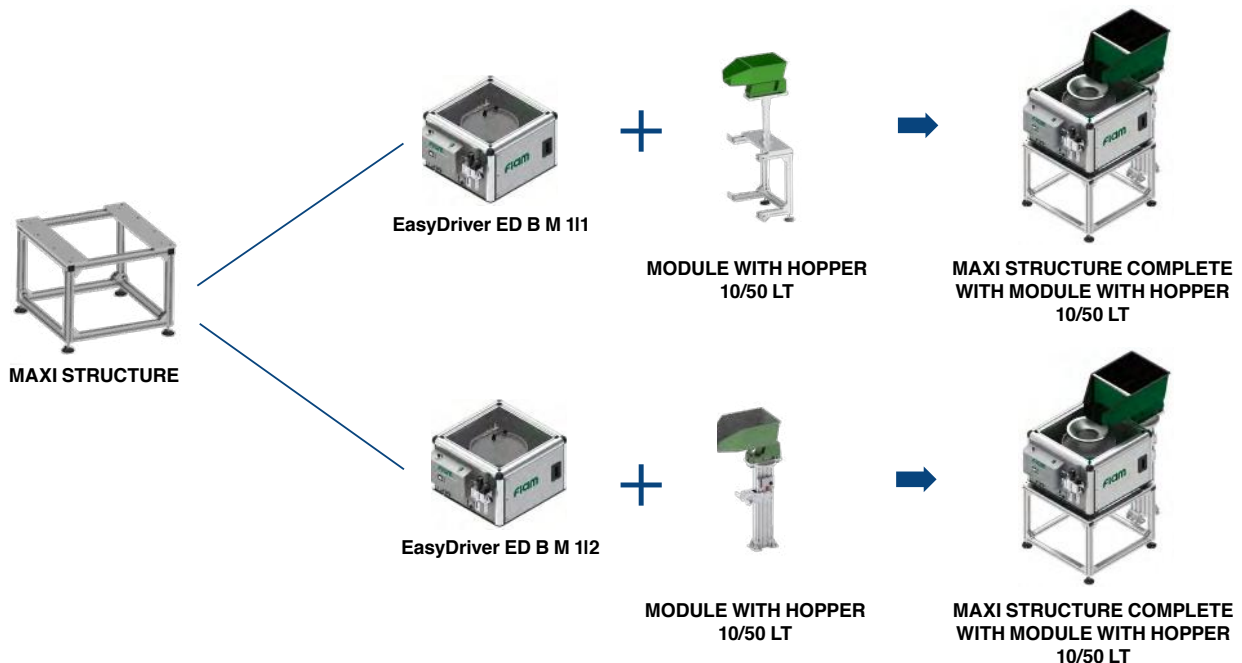
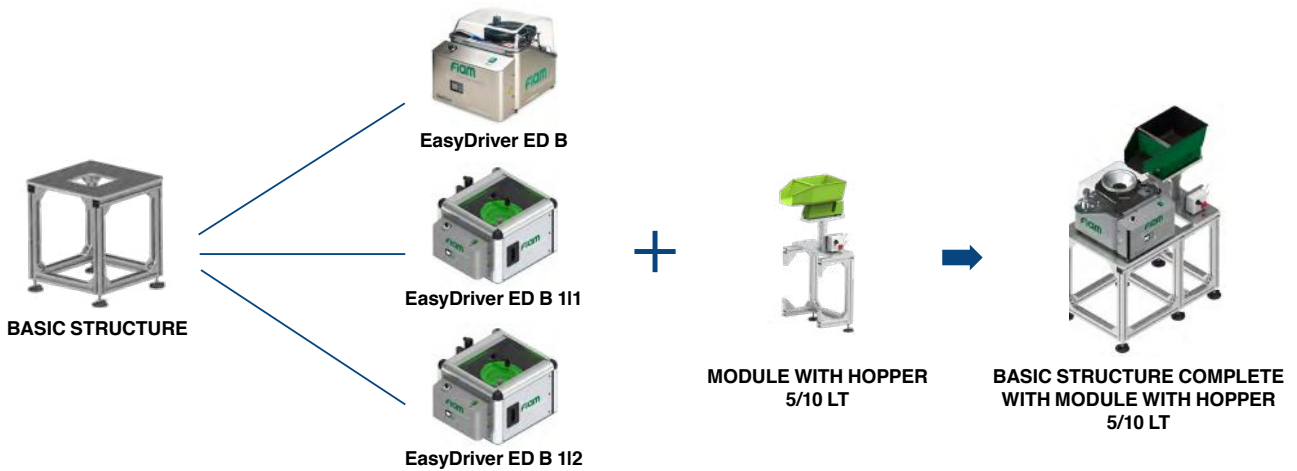



REQUEST A FREE QUOTATION!

By sending us the details through Data Entry 4.0 configurator, **which you can compile directly on our website**, you will quickly receive a no-obligation “turnkey” solution that will save you time and money!

<https://www.fiamgroup.com/en/request-a-quotation/>



<https://www.fiamgroup.com/en/etensil-the-fiam-electrical-revolution/>



**Fiam Utensili
Pneumatici Spa**
Viale Crispi 123
36100 Vicenza - Italy
Tel. +39 0444.385000
Fax +39 0444.385002
www.fiamgroup.com
info@fiamgroup.com

**Fiam France
Succursale**
73, cours Albert Thomas
69003 Lyon - France
Tel. +33 (0)9 70 40 73 85

**Fiam España
Sucursal**
Travessera de Gràcia, 11,
5ª planta
08021 Barcelona - España
Tel. +34 636808112

Meet us on   



Quality Management
System Certificate



Environmental Management
System Certificate